

Flailmower front/back

Safetymanual

original manual!

Model: FEFRONT125/155/175



Always read before use

DK·TEC

DK-TEC A/S Ærøvej 8, 5800 Nyborg Telefon: 66128222 E-mail: info@dk-tec.dk

1. GENERAL INFORMATION

I.1 INFORMATION ABOUT THE MANUAL

The using prescriptions shown in this Handbook must be carefully observed to obtain the best performances, to assure the greatest duration of the different parts and to avoid damages to the machine and accidents to the operator.

It is advised the careful reading of the present handbook, to deepen the knowledge of the MULCHER before starting to use it.

The present manual is to be considered an integral part of the machine, it must go with the machine in case of resale and till its demolition.

Some illustrations in this manual show particulars or accessories that could be different from those of your machine, some component could have been removed to assure the clearness of the illustrations.

The subjects dealt in this handbook are those expressly requested by the Directive 2006/42/EC and by the relatives technical standards.

On the machine are inserted apposite pictogram, which the operator will take care to maintain in perfect visual state and to replace when they are not more readable.

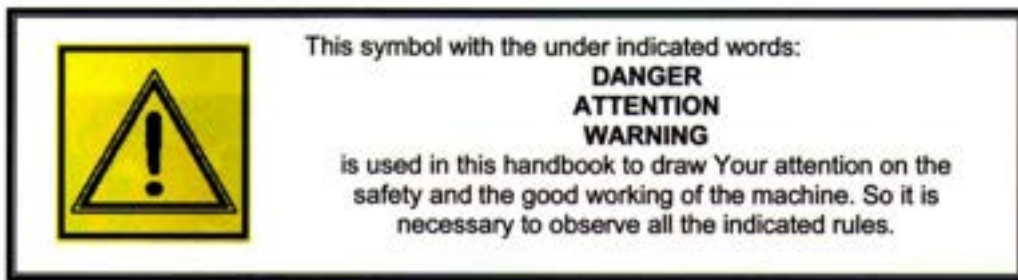

This Handbook has been written following the effective regulations at the moment of its printing. It is an integral part of the machine and must go with the machine with the Declaration of Conformity in case of resale.

1.2 IDENTIFICATION OF THE MACHINE

You will find on frame of each machine: the EC mark and a plate reporting the information about the constructor, the model and the serial number, the year of construction, the weight.

EC Identification plate



I.3 INFORMATION ABOUT THE MACHINE

Before leaving the production factory this specific model has been subjected to a severe testing to guarantee the greatest reliability.

I.3.1 Foreseen usages

The RMZ road mulcher for grass, residue of vegetables, bushes and pruning up to Ø 3-4 cm., with 3-point linkage Cat. II (Cat. I on request). Suited for tractors from 40 to 90 HP and ideal for clearing green areas, gardens, slopes, ditches, banks of watercourses, road side banks.



The shredders with openable hatchback door must be used exclusively with such door (with hydraulic or manual opening) COMPLETELY CLOSED, the use of such door is exclusively of maintenance (we remember that for any intervention on the machine all the instruction in the chapter of this handbook reported must be observed). A use different from the one specified is considered improper.



The machine must be used by one only operator. A use different from the one specified is considered improper.

The machine must be used exclusively by authorized, instructed and opportunely trained people.

This machine is usually used during the day, if exceptionally the night use or in condition of low visibility is requested, the lighting system of the tractor must be used.

Each arbitrary modification made to this machine, releases CLOVER from any liability for damages or lesions, serious too, that could occur to the operator, third person or things.

A correct use of the machine, a scrupulous observance of the here listed rules and the strict application of all the precaution to prevent possible dangerous situations, will avoid the danger of injuries or accidents, will let work the machine better and longer and will reduce faults to the minimum.

CLOVER DECLINES ALL RESPONSIBILITIES, OBJECTIVE AND SUBJECTIVE, IF THE RULES REPORTED IN THIS MANUAL ARE NOT OBSERVED

1.3.2 Contraindications

- be sure that on the ground to work there aren't stones or rock of notable dimensions (diameter upper to 10 -15 cm);
- make sure that on the ground to work there aren't tree stumps projecting over about 10cm and of diameter upper to about 10 — 15 cm;
- make sure that on the ground to work there aren't metal elements of every kind, in particular nets, cables, ropes, chains, pipes, and so on;
- observe and apply carefully the instructions of regulation of the height of the machine from the ground, however avoid that in the range of work of the machine till 50 meters other people could stand;
- it is advised never to work "Close to the ground" on wet grounds not to compromise the performance and the balancing of the machine, risking to damage the rotor too. In these cases the hoes are too much consumed, notable power is drawn from the

engine, there is the risk to HII inside the protective case of the rotor with pressed mud;
• a prolonged work "close to the ground" tends to petrify and to make the ground harder, getting its characteristics worst and compromising the good result of future cultivation.

1.3.3 Noise level

The noise testing have pointed out a Sound Pressure level equal to 84 dB(A) x 1 dB, measured in open field at a distance of 3 m. from the machine and at 1.6 m. on working land, in continuous maximum allowed working rate conditions.

According to these information it is recommended to wear an individual ear protection.

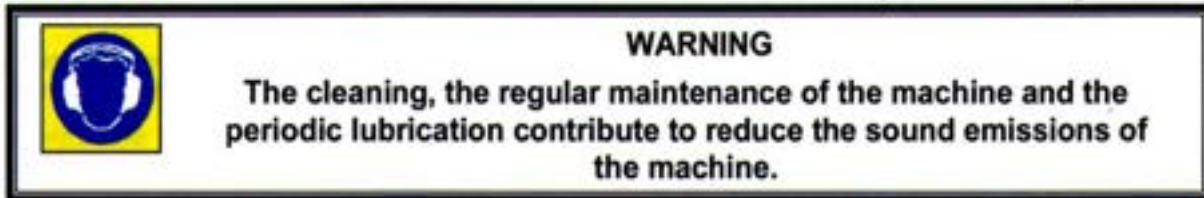

Though there is a connection between the sound emission and the exposure level, this datum can't be used to determine if it is necessary to take some precautions. In fact other factors exist that can affect the sound exposure level, such as for example the characteristics of the working environment and the presence of other noise sources. The information about the noise level emitted by the machine will however help the user or the employer in the writing of the valuation of the dangers and risks.

1.3.4 Storage

If the machine is not used for a long period it is necessary to store it in a sheltered place in order to protect it and to avoid dust accumulation. Before the storage we recommend to clean carefully the whole machine and to oil carefully the mechanic parts to protect them from the rust.

Before storing the machine for a long period, we recommend to operate as follows:

- wash carefully the machine;
- make a general sight checking of the machine to locate possible structural lesions, notice possible deep scoring on the painting, verify that the original safety pictogram are present in their right position, that they are complete and readable;
- grease all the mechanical parts, such as the tightening bolts, the joint shaft to the PTO shaft;
- recover, if possible, the machine in a covered room and lean the machine on wood boards on a flat surface;
- cover the machine with a sheet, binding it opportunely.

The used oil must not be dispersed in the environment, because, according to the effective law regulations, it is classified as special waste, and as such it must be given to the special collect centre. Please apply to the nearest Consortium of used oils.

1.3.5 Scrapping

In case of scrapping the machine should be disposed in appropriate dumps observing the effective legislation.

Before proceeding to the scrapping it is necessary to separate the plastic or rubber parts, the electric and electronic material.

Recover the possible run-down oils and dispose them in the appropriate collection centres. The parts completely made of plastic material, aluminium, steel, can be regenerated if collected in the special centers.

1.4 TECHNICAL DETAILS AND IDENTIFICATION OF THE COMPONENTS

These machines are suitable to low and medium power wheel tractors. They are composed of a supporting frame in electric-welded steel bringing the joints for the connections to the tractor, power a power transmission system composed of an angular dismissal, a pair of pulleys connected by trapezoidal belts and by an electronically balanced rotor knives-bearing.

The models of this manual are brought by the tractor through 3 points joint, and act on the ground with their own weight and rotation of the power-taking.







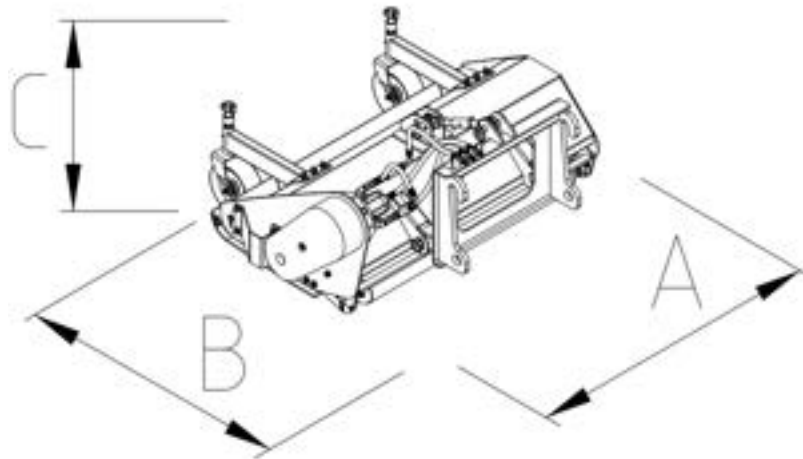



By regulating the height of the lateral slides, of the wheels and of the rear roller, it is possible to vary the working height of the machine.

These machines are suitable for forest and garden working.

TECHNICAL SPECIFICATIONS

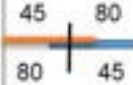
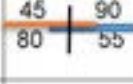
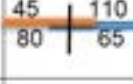
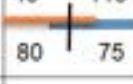

EFGCHD Flail Mower

Mod.		 HP							A	B	C	 KG
	CM	Min.	Max.	CM	n°	n°	n°	RPM	CM	CM	CM	KGS
EFGCHD125	125	25	55		20	40	3	540/1000	137	92	80	300
EFGCHD135	135	30	55		20	40	3	540/1000	147	92	80	310
EFGCHD145	145	30	55		22	44	3	540/1000	157	92	80	320
EFGCHD155	155	30	55		24	48	3	540/1000	167	92	80	330
EFGCHD165	165	30	55		26	52	3	540/1000	177	92	80	340
EFGCHD175	175	30	55		28	56	3	540/1000	187	92	80	350

Hydraulic system

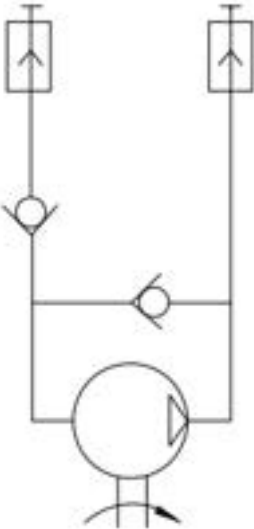

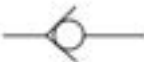
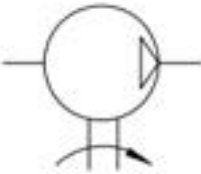
-  Quick connector
-  Single valve
-  Single direction motor

2. SAFETY PRESCRIPTIONS

Use the machine, make the periodic checks and the maintenance intervention in conformity with what is foreseen by the effective safety regulations.

The in-observance of the regulations or basis precautions about the safety may cause accidents during the working, the maintenance and the repairing of the machine.

The CLOVER SHREDDER has been produced and planed exclusively to cut grass, brushwood, prune remaining and corn trees, every other use modality must be explicitly authorized by the Company on a written document.

Any unauthorized modification on the machine excludes the company's responsibility.



Clover is not responsible for any possible damage caused by a not foreseen or inadequate use of the machine.

The machine must be used only by authorized, trained people, who know its potential dangers. If you have any doubt, do not hesitate to contact one of our technicians. The instructions written in this manual must be observed carefully.

2.1 SAFETY AND ACCIDENT- PREVENTION RULES



Verify carefully the machine before to turn it on

CLOVER can't foresee all the possible circumstances which might create a potential danger. The warnings presented in this document are therefore not exhaustive

-Observe, besides the warnings in this manual container, all the general safety and accident-prevention regulations. Do not let the machine work or make the maintenance till the instructions have not been read and understood.

-The signals applied on the machine give a series of important indications: their observance is useful to your safety.

- Make sure that all the safety pictogram are readable. Clean them and eventually replace them with new labels.

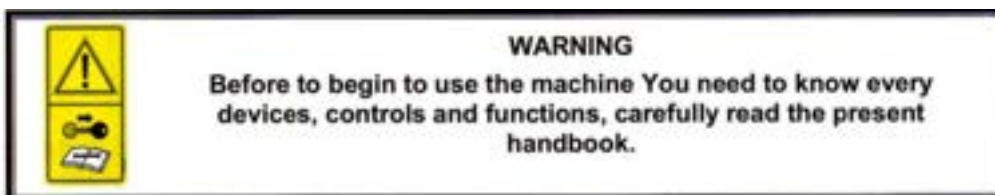

- Before using the machine make sure that all the safety devices are correctly placed and in a good state; in case of breakdowns or damages to the protections replace them immediately. In particular check that the front panels are present and complete, free to swing around the bolt on which they are hinged.

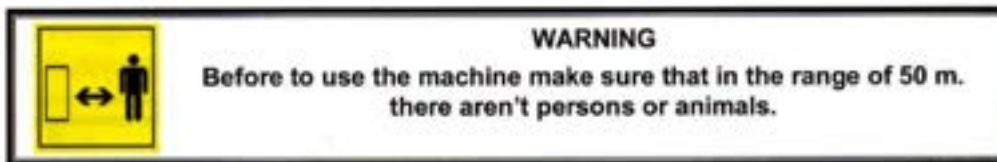
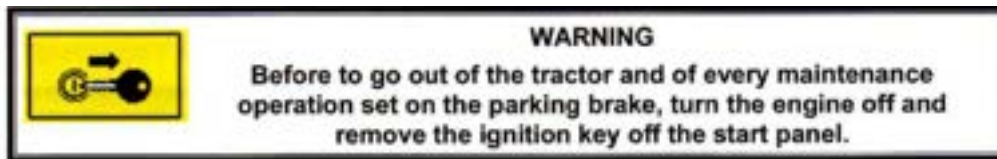

- The handbook must always be in an handing distance, allowing you to verify the operative cycle. If the book is lost or damaged you can ask to CLOVER for a copy.
- The machine must be used exclusively by authorized, instructed and trained people.
- The machine is planed to be used by only one operator.
- Do never work with this machine if you are tired, ill or under the influence of alcohol, drugs or medicines.
- It is recommended to the operator not to wear articles of clothing that could cause catching (sleeves without closed cuffs, belts, necklaces, bracelets, rings).



- During the use the shredder can give place to dust-emissions, in case of work with wet ground. It is advised to use tractors equipped with cabin with filters on the fan system or to use suitable protection systems of the respiratory tract such as anti-dust masks or masks with filter.
- Do not move the machine when the shredder is working.
- The machine must not be let unguarded when started.
- Check that the machine hasn't been damaged during the transport and in this case warn immediately CLOVER
- Keep the machine clean from foreign materials (rabbles, tools, various objects) that could damage the working or the operator.

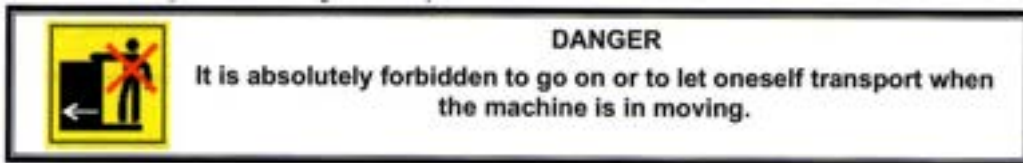

It is absolutely forbidden to go on or to let oneself transport when the machine is in motion.

- Make sure that the PTO shaft is correctly engaged after each connecting operation of the machine.
- Disconnect the machine from the tractor only on a compact and flat round, verifying that it is still and stable.
- Use the machine with enough natural light or, in alternative, use the light system of the tractor.

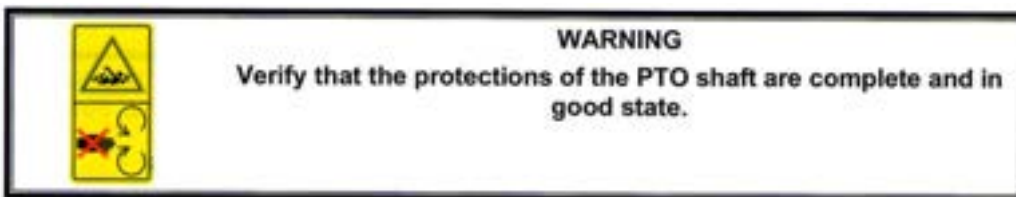

- In case of breaking or deterioration of the protections of the PTO shaft, take care of their immediate replacement.

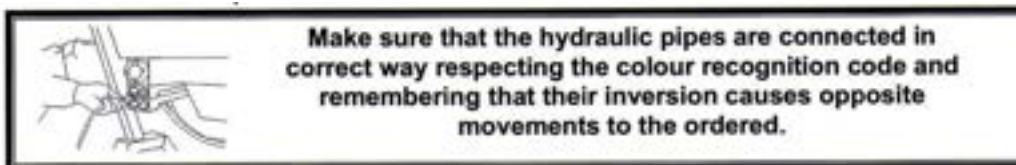

- Verify the wear state of the hydraulic pipes. In case of deterioration take care of their replacement. In any case replace the hydraulic pipes every 5 years.
- When the machine is not connected to the power unit, the hydraulic pipes must be connected on the special supports.

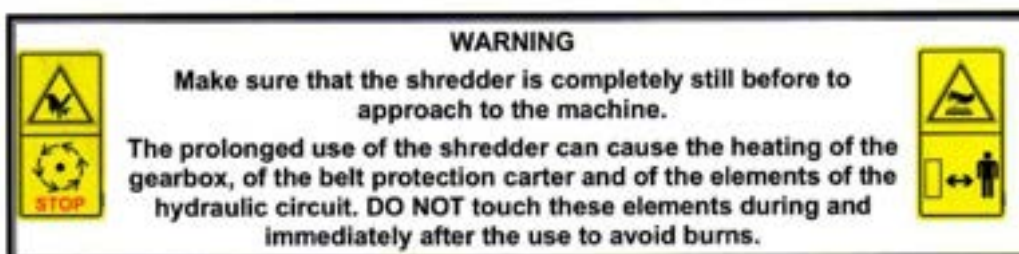
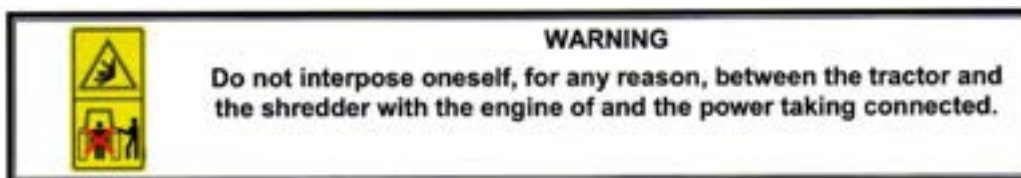

- Any changes on the machine may cause some problems. In this case the user will be the only responsible for possible accidents.

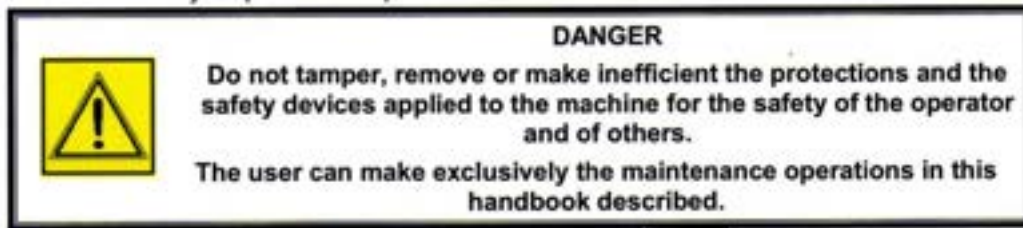

Use exclusively original spare parts of CLOVER firm.

CLOVER considers itself released from each possible responsibility in the case of:

- Improper use of the shredder by not trained people;
- Serious lack in the foreseen maintenance;
- Not authorized changes or interventions;
- Use of not original spare parts;
- Total or partial non-observance of the instructions;
- Non-observance of the common safety standards in the working range;
- Outstanding events

WARNING



BE SURE that the safety pictogram are readable. Clean them using a cloth, with water and soap. Replaced the damaged labels placing them in the correct position as it is described in the images below.

2.2 SAFETY SIGNALS

2.2.1 Location of the pictogram on the machine



2.2.2 Description of the pictogram



1. **WARNING** The operations of regulation and maintenance must be carried out after having read the use and maintenance handbook, with the machine still and the disengaged ignition key



2. **WARNING – DANGER** of fluids under pressure. Read the handbook before to intervene and in case of injury address to a doctor.



3. **WARNING** Make sure of the rotation direction and of the number of revolutions (540 rev./min.) of the power taking of the tractor before to insert the PTO shaft.



4. **WARNING – DANGER** Make sure that the shredder is completely still before to approach to it.



5. **WARNING – DANGER** of shearing of the feet. Keep the distance.



6. **WARNING** Possible throw of material and/or objects, *do not stand, get through or approach to the machine.*

Keep a minimum safety distance of 70 m from the machine



7. **WARNING** It is forbidden to go on the machine when it is in movement.



8. **WARNING** Danger of catching and dragging. Do not approach the hands to the transmission shaft in motion.



9. **WARNING** Do not stand between the tractor and the machine.

- 

10. DANGER of crash for the legs. Keep the proper distance.
- 

11. DANGER of squashing / shearing of the hands.
- 

12. WARNING Hot surface. Keep the proper distance
- 

13. WARNING Do not remove or open the protection carters till the belts are completely still
- 

14. WARNING DANGER of squashing. Do not stand in the move and side shifting zone of the machine.
- 

15. WARNING: for the lifting, hook the machine exclusively in the indicated points.
- 









16. Use the requested Individual Protection Devices.
- 
17. Greasing points (see par. 6.4)

IMPORTANT: Safety valves on these machines can not be removed, otherwise it will cause big damage to machines or people would be injured.

3. TRANSPORT AND INSTALLATION

3.1 UNPACKING AND POSITIONING

Take the maximum care to the safety during the loading and unloading operations, that shall be performed by qualified personnel (slingers, truck operators, and so on).

For the transport the machine must be positioned on pallets, fixed with suitable belts, and moved through a loader with a fit lifting ability.

Do not lift the machine with belts.



For the lifting of the machine use safety hooks or cables of suitable ability to insert in the preset eyebolts for the lifting indicated by the pictograms applied on the machine.

3.2 CHECK OF THE LIFTING CAPABILITY AND OF THE STABILITY OF THE TRACTOR

Verify the lifting capability and the stability of the tractor through the following formula and if necessary apply frontally the ballasts.

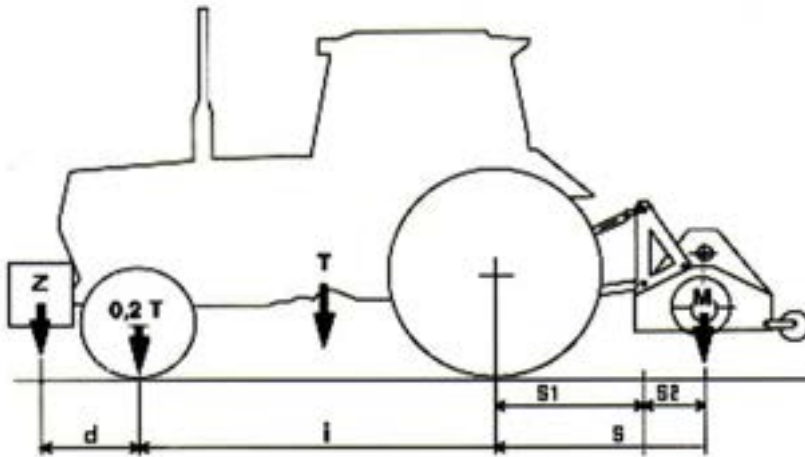

$$M \times S \leq 0,2 T \times i + Z (d + i)$$

$$M < 0,3 T$$

i	=	axle base wheels tractor
d	=	distance of the front axle from the ballasts
S	=	overhang of the rear axle of the operator machine S = S1 + S2
S1	=	distance of the tractor front axle to the end lifting arms
S2	=	distance of the shredder barycentre to the centre holes lifting pins
T	=	mass of the tractor + 75 kg (operator)
Z	=	Mass of the ballasts
M	=	mass of the whole loaded machine



DANGER!

It is obligatory to verify the lifting ability and the stability of the tractor to avoid its turnover and/or loss of adhesion of the steering wheels.

4. CONNECTION TO THE TRACTOR

The behaviour on the road, the steer and brake capacity are influenced by the used tools. The front axle of the tractor is lightened in relationship to the weight attached at the moment of the coupling to the lifting arm: the loading of the front axle must be at least 20% of the weight of the empty tractor.

Before the connection of the machine to the 3 points joint, position the safety device of the tractor to make impossible the unwanted and/or casual lifting and lowering.

The 3 points joint of the tractor and of the machine must coincide or be adapted.

In the rods zone of the rear lifting arms of the tractor there is the danger of injury owing to squashing and cutting points.

Do not use the outside control for the lifting of the machine.

In the transport position block the side halt of the rods and the control level of the lifting.

4.1 CONNECTIONS



4.1.1 Assembly of the shredder and regulations

The machine is equipped with bolts for the 3 points joint of the tractor.

For the connection of the structure of the machine to the tractor operate as follows:

- Approach the tractor to let the lifter bars coincide with the 3 points joint and connect them through the bolts on issue.

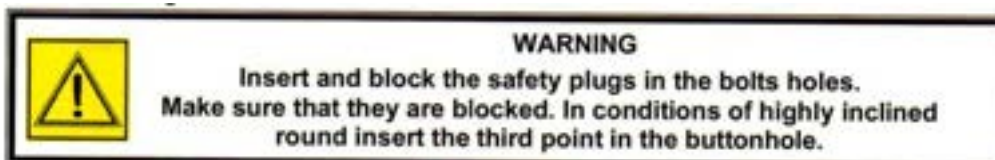

-Connect the third point to the upper joint and regulate it to position the machine in a parallel way to the ground. Verify that the knives or the hammers of the rotor shaft, when the machine is to the round, don't touch the round during the rotation. In the versions equipped with slides verify that these lean on the round along its whole surface.

To avoid that the knives or the hammers go into the ground it is necessary to regulate the height of the rear roller lightening the blocking screw and inserting it in the chosen hole.

- Lift the machine and acting on the rods of the lifter bars block the movement.

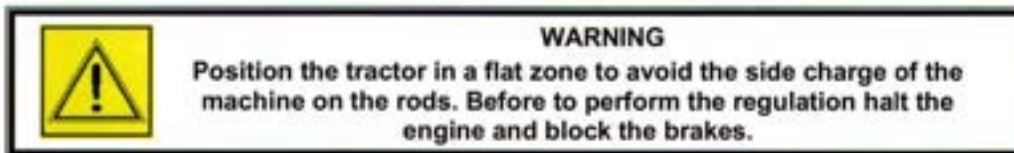

4.1.2 Connection to the PTO shaft

After having executed these operations you can connect the transmission PTO shaft of the power taking to the grooved shaft of the gearbox of the machine (covered by a protection counter guard) and then to the power taking of the tractor:

- clean and grease the power taking;
- grease, if necessary, the PTO shaft following the indications given by the producer of the PTO shaft (see Use and Maintenance Handbook of the PTO shaft):
- clutch the PTO shaft observing the mounting sense prescribed by the producer and indicated on the outside covering of the protection.
- Hitch the anti-rotation chain.
- Make sure that the anti-withdraw safety block (push button) is correctly inserted and blocked in its own housing.

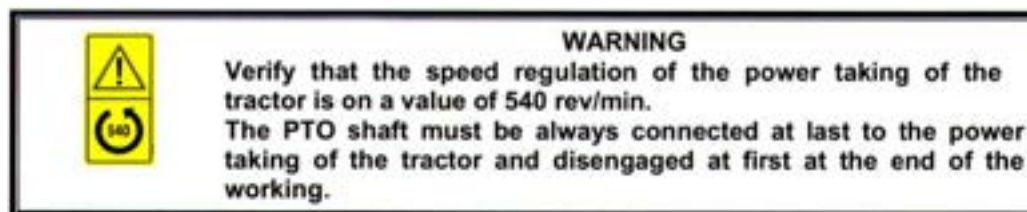

When disengaged, the PTO shaft, must be connected to the apposite support.
For a correct and sure working of the machine use exclusively PTO shaft with EC mark.
The length of the PTO shaft must be suitable to the kind of tractor that is used.

CLOVER is not responsible for any damages caused by a non correct use of the cardan transmission.

4.1.3 Hydraulic connections for lateral shifting

Switch the engine off (if on), set the handbrake on and remove the ignition key off the start panel

Verify that there isn't pressure in the hydraulic system of the tractor.

Connect the hydraulic pipes with rapid clutch to the tractor after having checked that all the joints are clean and in very good preservation state.

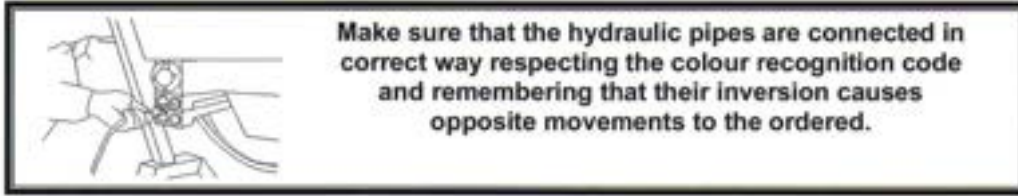

Give pressure to the hydraulic system, verify that there aren't drippings and that the connection is correct.

As the shredding operations are finished, the hydraulic pipes released from the tractor must be fixed in the apposite supports for this purpose foreseen.

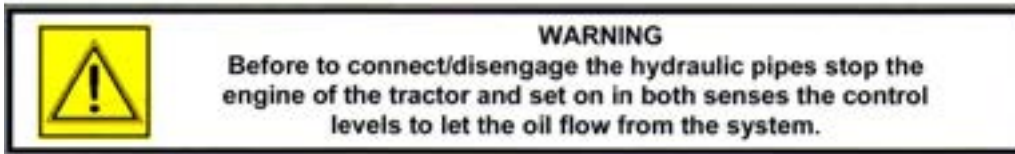

Before connecting, turn the hydraulic pipes off, stop the engine of the tractor and set on in both senses the control levels to let the oil flow from the system.

5. USE OF THE MACHINE

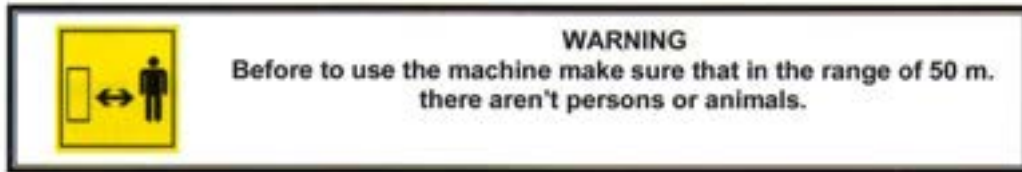

Before starting to work you need to regulate the machine to obtain a good working trim (see "Assembly and regulation", par. 4.1.1).

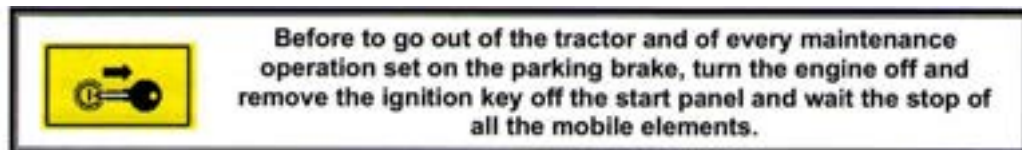

For a very good work we recommend to proceed to an advancement speed of 2,5 km/h on grass round and of 2,0 km/h on pruning residual.
During the work do not take curves with the machine to the ground, nor work in reverse.

Always lift the shredder for the direction changes and the curves, inserting first the power taking.

During the use the shredder can give place to dusts emissions, in that case you are working with a dry ground. We recommend to use tractors equipped with cabin with filters on the fan system or, to use suitable system for the protection of the respiratory tract such as anti-dust masks or masks with filter.

6. MAINTENANCE

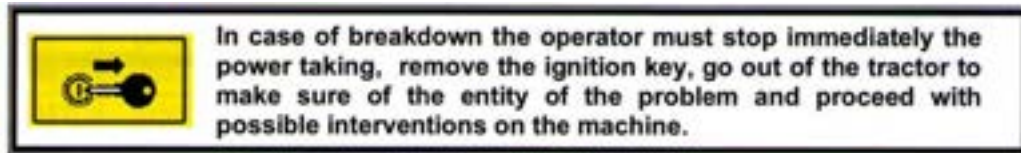

It is advised that all the maintenance operations must be performed by qualified and trained people, with the machine still and disengaged from the tractor.

It is necessary to verify daily the wear state of the knives, of the hammers and their connecting points, replacing immediately the ones that are worn or damaged because their breaking may cause dangerous projections of components.

6.1 ROTOR

The rotor shaft has been preliminarily balanced: in case of replacement of a tool, it is advisable to replace all the series. To assemble not original tools can cause vibrations of the machines or breaking of the rolling bearings.

The replacement of the damaged parts must be performed exclusively by specialized people.

For the knives replacement interventions it is necessary to apply to specialized people making use of the assistance service by CLOVER or its dealers.

6.2 FRONT PROTECTION BARS

The protection bars must always be in good state to avoid possible throw of materials in the front zone.

Immediately replace such parts even if they're lightly bended or warn.

For the bars replacement it is necessary:

- To unscrew the fixing screw of the bolt on the left side of the machine and withdraw the fixing bolt
- Replace the damaged bars
- Take care of the clamping of the fixing screw of the bolt.

Use exclusively original spare parts

6.3 ORDINARY MAINTENANCE

- Perform the maintenance with the machine disconnected by the tractor and opportunely positioned.
- Any maintenance work, regulation and cleaning must be performed with the machine to the ground, the engine of the tractor turn off, power taking disengaged, handbrake set on, ignition key disengaged and removed from the start panel
- Each 4 hours of work check the tension of the belts, You must always must care about their regulation



Perform this regulation only with the tractor turn off and power taking disengaged, remove the ignition key, wait until all the mechanisms are stopped.

6.3.1 Regulation of the belts

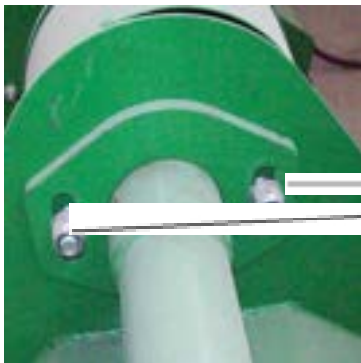

Loosen the screw **A** and **B** that block the support shaft
And loosen the counter nut **C**

Loosen the screws that block the gearbox on the support shaft **D**



**6.3.2
AND**

LUBRIFICATION

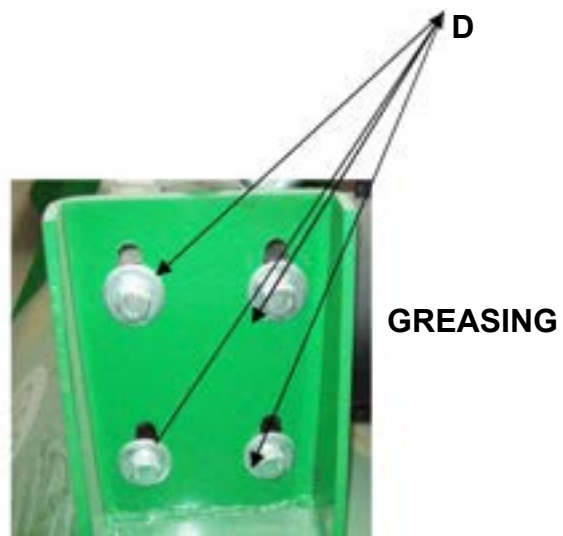

Each **4 hours** of work:

- Verify camping of the nuts
- Grease with lithium oil when it is indicated by the symbol **GREASE**

6.4 INCONVENIENCES AND REMEDIES

INCONVENIENCES	CAUSE	REMEDY
Clogging of hammers/knives	Rotor speed is too low	Increase rotor speed
Excessive wear of hammers/knives	Rotor speed is too high	Decrease rotor speed
Shredder vibrates during works	<ul style="list-style-type: none">• Foreign matter stuck in between hammers/knives broken• Bolts of the rotor shaft support have come lose	<ul style="list-style-type: none">• Remove foreign matter• Replace hammers• Lock bolts

Conform to the following European Directives and harmonized standards

2006/42/EC

Machinery Directive

EN ISO 4254-1:2015

Agricultural machinery – Safety Part 1: General requirements

EN ISO 4254-12:
2012+A1:2017

Agricultural machinery - Safety Part 12: Rotary disc and drum mowers and flail mowers