

Operator's Manual

Wheel Loader

Model	H160
Edition	1.0
Date	May 21th, 2024

Manufacturer keeps abreast of the latest technical developments and constantly improve the products.

We sometimes may not have enough time to upgrade in time.

Technical data, dimensions and weights are given as an indication only.

As for omissions and errors, please understand and forgive.

Catalogue

Introduction	1-1
General information on the Operator' s Manual.....	1-1
General information on machine safety.....	1-1
Machine outside view	1-2
Safety instructions	2-1
Identificatio ns of warnings and dangers	2-1
Designated use and exemption from liability	2-2
General conduct and safety instructions	2-3
Organizational measures.....	2-3
Selection and qualification of staff, basic responsibilities	2-4
Safety instructions regarding operation	2-5
Normal operation	2-5
Attachments.....	2-7
Transporting, towing, loading.....	2-7
Safety instructions for maintenance	2-8
Maintenance work on Cab	2-10
Warning of special hazads	2-10
Electric energy	2-10
Gas, dust, steam , smoke	2-10
Hydraulic	2-11
Noise.....	2-11
Oil, grease and other chemical substances.....	2-11
Battery.....	2-11
Tyres.....	2-11
Operation	3-1
Description of control elements.....	3-1
Driving position overview	3-2
Multifunctional touching screen dash board	3-4
Dash board, switch combination, joystick (overview)	3-4
Switch combination.....	3-7
Use wheel loader	3-11
Safety instructions on testing.....	3-11
Operator' s important information	3-11
The run-in period of wheel loaders	3-11
Checklist	3-12
Staring checklist.....	3-12
Operation checklist.....	3-13
Packing checklist	3-13
Engine cover lock	3-14
Opening/cloaking the engine	3-14
Diesel oil level sensor.....	3-14
Putting the diesel engine into operation.	3-15
Preparing to start the engine.....	3-15
Starting the engine.....	3-16
Avoid running the engine under low-load conditions....	

.....	3-16
Stopping the engine	3-16
Jump-starting the engine (external battery)	3-17
Safety instructions regarding external battery starting the engine	3-17
Providing external starting aid	3-17
Steering system.....	3-17
Steering column angle adjustment.....	3-17
Check the steering system.....	3-18
Accelerator pedal	3-18
Speed control with the accelerator pedal	3-18
Braking pedal.....	3-18
Specific information on brake pedal	3-18
Braking with the brake pedal.....	3-19
Parking brake	3-19
General instructions about the parking brake	3-19
Applying the parking brake.....	3-19
Driving the machine	3-20
Selecting a speed range	3-20
Changing directions(forward/backward).....	3-20
Cruise control.....	3-21
Using the cruise control.....	3-21
Headlights and working lights.....	3-21
Operation on headlights and working lights	3-21
Signal lights and emergency stop switch	3-22
Turning indicator operation.....	3-22
Rotating warning signal lights operation	3-22
Emergency stop switch	3-22
Seat.....	3-23
Horizontal adjustment	3-23
Backrest adjustment	3-23
Seat belt.....	3-23
Specific instructions regarding the seat belt.....	3-23
Fastening the seat belt.....	3-24
Unfasten the seat belt	3-24
Longer/shorter lap belt adjustment	3-24
Do not tow the machine.....	3-25
Never tow the machine.....	3-25
Decommissioning the machine temporarily.....	3-26
Parking/stopping the machine.....	3-26
Decommissioning the machine for a longer time... ..	3-26
Loading and transporting the machine on a vehicle....	3-28
Safety instructions regarding loading on a transport vehicle.....	3-28
Loading and tying down the machine.....	3-29
Loader unit control lever (overview).....	3-30
Control lever (joystick) for lift and tilt arms and 3rd and 4th hydraulic control circuit	3-30
Locking/unlocking attachments on the quick change....	

.....	3-31
Operation of hydraulic attachments	3-31
Operation of the 3rd control circuit.....	3-31
Continuous output of the 3rd control circuit.....	3-32
4th control circuit(option).....	3-32
4th hydraulic circuit connection	3-32
Operation of 4th hydraulic circuit	3-33
Continuous output of the 4th hydraulic circuit.....	3-33
Emergency lowering of loader unit in case of diesel engine breakdown	3-33
Lowering or raising.....	3-33
Pressure relief on the quick hitch couplers	3-34
Equipping the machine with a standard bucket.....	3-35
Fitting a standard bucket onto the quickhitch	3-35
Working with a standard bucket.....	3-36
Fields of application for bucket.....	3-36
Safety instructions for working with the bucket	3-36
Safety instructions for transporting material in a full bucket.....	3-36
Loading loose material.....	3-37
Loading if the material is hard to penetrate.....	3-37
Removing material/digging in soft soil.....	3-38
Removing material / digging in hard soil.....	3-39
Loading heaped material (non-compacted material)	3-39
.....	3-39
Loading heaped material (compacted)	3-40
Grading	3-40
Practical hints for loading vehicles	3-40
Finish work.....	3-40
Fitting a multipurpose bucket.....	3-41
Picking up a multipurpose bucket with the quickhitch..	3-41
.....	3-41
Connecting the hydraulic lines of a multipurpose bucket to the wheel loader	3-41
Working with the multipurpose bucket	3-42
Fields of application for multipurpose bucket.....	3-42
Safety instructions for working with the multipurpose bucket.....	3-42
Removing the multipurpose bucket from the quick hitch.....	3-42
Safety instructions for transporting material in a full multipurpose bucket	3-43
Grading and scraping	3-44
Removing and spreading material in thin layers.....	3-44
Pulling out material from slopes.....	3-45
Moving material with longer reach.....	3-45
Picking up remaining material completely.....	3-45
Grabbing bulky material	3-46
Pulling out and setting posts	3-46

Backfilling round gravel and precise unloading	3-47
Unloading from the bottom of the bucket for increasing dump heights.....	3-47
Fitting pallet forks	3-48
Picking up pallet forks with the quick hitch.....	3-48
Removing the pallet forks from the quick hitch.....	3-48
Working with the pallet forks.....	3-49
General safety instructions regarding the pallet forks....	3-49
Adjusting the fork arms of the pallet forks.....	3-51
Fields of application for pallet forks.....	3-51
Picking up loads with the pallet forks.....	3-52
Transporting loads with the pallet forks	3-52
Trailer coupling	3-53
General information on the trailer coupling	3-53
Trailer loads on the trailer coupling.....	3-53
Trailer coupling operation.....	3-53
Final decommissioning of machine	3-54
General information on decommissioning	3-54
Preparing disposal	3-54
Disposal	3-54
Troubleshooting	4-1
Engine trouble	4-1
Maintenance	5-1
Important information on maintenance and service work...	5-1
Important information for maintenance personnel..	5-1
Fuel system.....	5-2
Safety instructions for refueling.....	5-2
Diesel fuel specification	5-2
Stationary fuel pumps	5-2
Refueling	5-3
Check/clean the fuel filter.....	5-3
Engine lubrication system.....	5-4
Safety instructions regarding inspections and maintenance work on the engine.....	5-4
Checking the engine oil level and oil filter.....	5-4
Filling up engine oil.....	5-5
Engine and hydraulics cooling system.....	5-6
General instructions regarding cooling system maintenance.....	5-6
General checks and cleaning work	5-6
Cleaning the radiator fins of the oil/water radiator..	5-7
Checking the coolant level	5-8
Filling up coolant.....	5-9
Air filter	5-10
Checking the air filter for dirt	5-10
Replacing the air filter cartridge	5-11

V-belt.....	5-12
Checking V-belt tension	5-12
Retightening the V-belt	5-12
Hydraulic system	5-13
Safety instructions regarding maintenance of the hydraulic system	5-13
Monitoring the hydraulic oil and the reflux filter ...	5-14
Checking the hydraulic oil level	5-15
Filling up hydraulic oil	5-15
Checking hydraulic pressure lines	5-16
Safety instructions regarding pressure line checks.	5-16
Lubrication work.....	5-17
Safety instructions regarding lubrication work	5-17
Lubricating the rear axle oscillation-type bearing..	5-17
Lubricating and steering system.....	5-17
Lubricating the loader unit	5-18
Maintenance of the brake system	5-19
Specific safety instructions regarding the brake system	5-19
.....	5-19
Tyres	5-19
Daily tyre checks.....	5-19
Wheel change.....	5-20
Electrical system.....	5-21
General instructions	5-21
Safety instructions regarding the electrical system and the battery.....	5-21
Checking/replacing the battery	5-22
Inspection and maintenance work on the electrical system regularly	5-23
Checking the alternator	5-23
Checking/replacing fuses and relays.....	5-24
General cleaning and maintenance work	5-25
Safety instructions regarding general cleaning work.....	5-25
.....	5-25
Cleaning with washing solvents.....	5-25
Cleaning with compressed air	5-25
Cleaning with a high-pressure cleaner or steam jet	5-25
.....	5-25
Cleaning with volatile and flammable anticorrosion agents and sprays.....	5-25
Cleaning the seat belt.....	5-26
Cleaning the exterior of the machine	5-26
Cleaning the engine compartment.....	5-26
Checking screw connections.....	5-26
Checking pivots and hinges	5-26

1 Introduction

1.1 General information on the Operator' s Manual

This Operator's Manual applies to the wheel loader model H160 and contains important information on how to work safely, correctly and economically with the machine.

1.2 General information on machine safety

Your own safety, as well as the safety of others, depends to a great extent on how the machine is operated. Therefore, carefully read and understand this manual prior to the first drive. As a rule, keep the following in the mind:

Careful and prudent working is the best way to avoid accidents. Regular maintenance and service work is absolutely necessary. Extensive maintenance and repair work must always be carried out by an expert with appropriate training.

Insist on using original spare parts when carrying out maintenance and repair work. This ensures operational safety and readiness of your machine, and maintains its value. The machine's permits, certifications, registrations, etc., may be withdrawn if machine parts with a prescribed conditions or quality, or machine parts are not stable.

1.3 Machine outside view

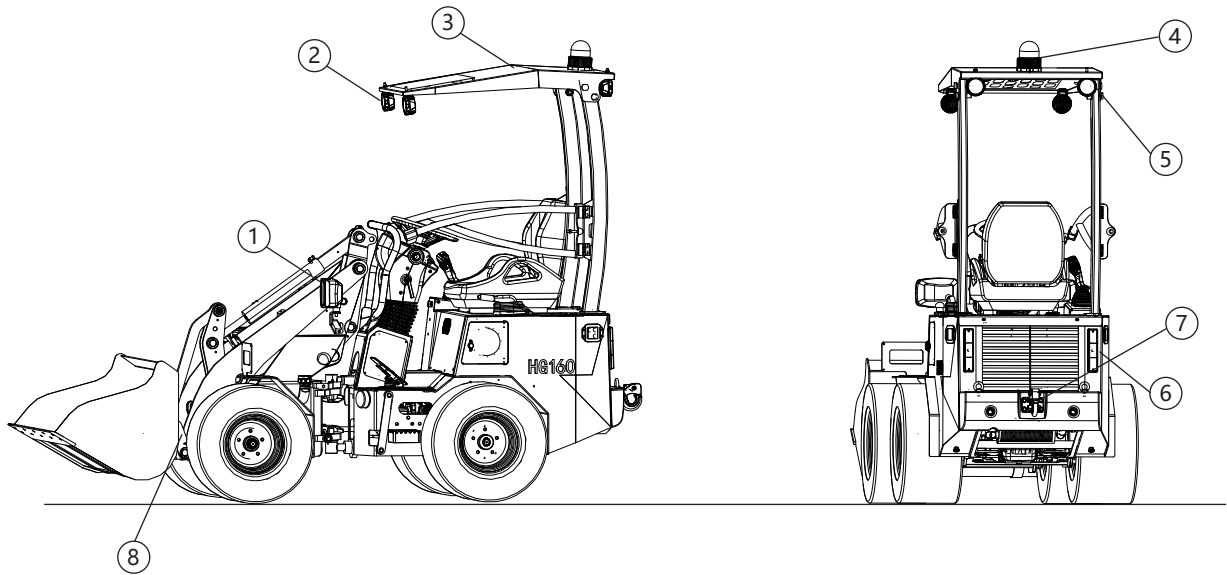

Item	Description
1	Headlight with turn indicator
2	Front working light
3	FOPS + ROPS
4	Rotating warning light
5	Rear work light
6	Brake+width indicator+turn combination light
7	Traction device
8	Quick hitch device for attachments

Introduction

Note:

2 Safety instructions

2.1 Identifications of warnings and dangers

When reading this manual, please keep in mind with the following symbols:



Danger!

Failure to observe the instructions identified by this symbol can result in personal injury or death for the operator or other persons.

☞ Measures for avoiding danger to life and limb of the operator or other people.



Caution!

Failure to observe the instructions identified by this symbol can result in the damage of the machine.

☞ Measures for avoiding danger for the machine.



Important !

This symbol identifies instructions for a more efficient and economical use of the machine.



Environment!

Failure to rely on this symbol can result in damage to the environment.

If environmentally hazardous material (e.g. waste oil) is not subject to proper use or disposal, the environment is in danger.

2.2 Designated use and exemption from liability

- Carrying or transporting accompanying persons in the cab or on the wheel loader is not allowed!
 - Carrying or transporting persons in the attachments (e.g. bucket, pallet forks) is not allowed!
 - The machine cannot be used for transport jobs on public roads!
 - Fire hazard due to hot engine silencer-the machine may not be used in areas posing a fire hazard (hay or straw facilities) !
 - This machine is intended for:
Moving earth, gravel, coarse gravel or ballast and rubble, and for applicants with attachments.
Every other applicants is regarded as not designated for the use of the machine. The manufacturer will not be liable for damage resulting from use other than mentioned above. The user alone will bear the risk.
- Designated use also includes observing the instructions in the Operator's Manual and observing the conditions of maintenance and service !
- Understand and comply with regulations and rules in your country/region. Manufacturer will not be responsible for any damages without complying with these regulations and rules.
 - If user transforms the machine without proper authorization and uses attachments, equipments, spare parts and optional equipments that are not released by the manufacturer, there will be bad effect on the safety of machines. The manufacturer will not be reliable for the damages.
 - The manufacturer shall not be reliable for personal injury and property loss.

2.3 General conduct and safety instructions

Organizational measures

- The machine has been designed and built in accordance with state-of-the-art standards and the recognized safety regulations. Nevertheless, its use can constitute a risk to life and limb of the user or third parties, or cause damage to the machine and to other material property!

- The machine must only be used in technically perfect condition in accordance with its designated use and the instructions set forth in the Operator's Manual, and only by safety-conscious persons who are fully aware of the risks involved in operating the machine. Immediately rectify and functional disorders, especially those affecting the safety of the attachment!

Basic rules:

Before starting up the machine, inspect the machine for safety in work and road operation!

- Careful and prudent working is the best way to avoid accidents!

- In addition to the Operator's Manual, observe and instruct the operator in all other generally applicable legal and other mandatory regulations relevant to accident prevention and environmental protection. These compulsory regulations may also deal with handling hazardous substances, issuing and wearing personal protective equipment, or traffic regulations!

- With regard to specific operational features, e.g. those relevant to job organization, work sequences or the persons entrusted with the work, supplement the Operator's Manual by corresponding instructions, including those relevant to supervising and reporting duties.

- Persons entrusted with work on the machine must have read and understood the manual and in particular, chapter "Safety Instructions" before starting work. This is especially important for persons working only occasionally on the machine, e.g. maintenance.

- User/owner must check and confirm whether operators work in accordance with the manual, and understand risks and safety factors!

- User/owner must commit himself to operate and keep the machine in a perfect condition, and, if necessary or required but law, to require the operating or serving persons to wear protective clothing!

- If there are safety-relevant modifications or changes on the machine or its behavior, stop the machine immediately and report the malfunction to the competent authority/person!
Safety-relevant damage or malfunctions on the machine must be rectified immediately!

- Without the approval of the manufacturer, any modifications which may influence the safety of the machine cannot be made.

- Spare parts must comply with the technical requirements by the manufacturer!
- Replace hydraulic hoses within stipulated and appropriate intervals even if no safety-relevant defects have been detected!
- Before working on or with the machine, remove jewelers, and tie back hair and do not wear loose-fitting clothes, which may result in personal injury.
- Keep the machine clean, this will reduce fire and injury risk.
- Comply with all safety, warning and information signs and labels on the machine!
- Adhere to prescribed intervals or those specified in the manual for routine checks and maintenance work!
- Tools and workshop equipments adapted to the task are absolutely indispensable for carrying out service, inspection, maintenance or repair work!

Selection and qualification of staff, basic responsibilities

- Any work on or with the machine must be carried out by reliable staff only. Do not let unauthorized persons drive or work with the machine!
- Employ only trained or instructed staff on the machine, and clearly define the individual responsibilities of the staff for operation!
- Define the machine operator's responsibilities, including complying with traffic regulations!
- Only trained technical staff can carry out the work on the electrical system and equipment, on the chassis and the steering and brake systems.
- Work on the hydraulic system of the machine must be carried out only by staff with special knowledge and experience in hydraulic system!
- Seal off the danger area if it is not possible to keep a safe distance!
- Stop work if persons do not leave the danger area in spite of warning!

Danger area:

The danger area is the area in which persons are in danger due to

- machine
- work equipment
- other equipment or load!
- This also includes the area affected by falling material, equipment or by parts which are thrown out.
- The danger area must be extended!

2.4 Safety instructions regarding operation

Normal operation

- Avoid any operational mode that might be prejudicial to safety !
- Before beginning work, familiar yourself with the surroundings and circumstances of the work site.
- Take the necessary precautions to make sure the machine is used only when in a safe and reliable state!
- Operate the machine only if all protective and safety-oriented devices are in place and fully functional!
- Check the machine at least once a day/per work shift for visible damage and defects.
- When meeting malfunctions, stop the machine immediately and lock it! Have any defects rectified immediately!
- Start and operate the machine only when sitting on the seat!
- Before leaving the seat, apply the parking brake and stop the diesel engine!
- Carry out, start up and shut down procedures in accordance with the manual!
- Before operating the machine, make sure nobody is in danger area!
- Before driving the machine, and after interrupting work, check whether brakes, steering, signaling and light systems are functional!
- Before driving the machine, check whether the supplement equipment and the attachments have been safely connected!
- Please comply with traffic regulations when driving on the public road!
- Always switch on the lights in conditions of poor visibility and after dark!

- **No raising, lowering or carrying persons in the work equipment!**
- **Installing a man basket or a working platform is prohibited!**

- When crossing underground passages, bridges and tunnels, or when passing high voltage electrical circuit, always make sure there is enough clearance!
- Always keep at a safe distance from the edges of slopes and deep holes!
- When working in enclosed areas, please mind:
 - Height of the ceiling/clearances
 - Maximum load of ceilings and floors
 - Sufficient room ventilation-danger of poisoning!

- Avoid any operation that might be a risk to machine stability !
- If driving across a slope cannot be avoided, bear in mind the tilting limit of the machine !

Always keep the attachments/work equipment close to the ground.
This also applies to driving downhill !

When working or driving across a slope, the load must be on the uphill side of the machine !

- Before leaving the seat, always secure the machine against unintentional movement and unauthorized use!

- Lower the attachments to the ground!

- Before starting work, please check whether:

All safety devices are properly installed and functional!

Prepare an approved warning triangle, hazard warning light and first aid kit !

- Before moving the machine or before taking up work:

Make sure visibility is sufficient (do not forget rear view mirrors)!

Adjust correct seat position (you must be able to press the brake pedal as far as it will go)

When driving or working, never adjust the seat!

Fasten your seat belt!

Inspect the immediate area (children)!

In the work area, the operator is responsible for third parties!

- Be careful when handling fuel, make sure fuel does not come into contact with hot parts!

- Do not smoke during fueling, and avoid fire and sparks! Stop the engine when fueling and do not smoke!

- Never get on or off a moving machine! Never jump off the machine!

- If the lights of the machine are not sufficient, please provide additional lighting of the work area!

- Do not use working lights when driving on public roads, which may influence the driving sight of the drivers.

Attachments

- Prior to driving on public roads, remove all attachments which cannot be secured in compliance with the legal regulations.
- Attachments and counterweights affect handling, as well as the steering and brake capability of the machine !
- Fit the attachments with the specially required devices only !
- Before uncoupling or coupling hydraulic lines(hydraulic quick couplers):
 - Stop engines
 - Release the pressure in the hydraulic system. (P3-P35)
- Before careful when coupling attachments!
- Secure the attachments against unintentional movement!
- Operate the machine only if all protective facilities have been installed and are functional.
- When installing attachments manually, secure the machines against unintentional movement!
- Make sure the attachment is safely locked in the quickhitch, the lock pin must be visible on either side.
- Before installing the attachments, make sure loading units against movements!
- Be careful and be cautious to operate, because coupling attachments can result in personal injuries.

Transporting, towing, loading

- The machines must be loaded and transported only in accordance with the Operator's Manual !
- This machine cannot be towed, if towing will cause permanent damage for the loader!
- Use only suitable means of transport and lifting gear of adequate capacity/payload!
- Safely secure the machine on means of transport, use suitable slinging points and load-securing devices!

2.5 Safety instructions for maintenance

- Avoid any optional mode that might be prejudicial to safety !
- Comply with the maintenance period regulated in the manual !
- Unauthorized personnel cannot repair, fix or operate the loader !
- In any work concerning the operation, conversion or adjustment of the machine, observe the start-up and shut-down procedures set forth in the manual!
- If required, secure the maintenance area appropriately in order not to hurt persons.
- Before carrying out service, maintenance and repair work, attach a warning label, such as " Repair work-do not start machine!", to the ignition lock/ steering wheel or to the control elements. Remove the ignition key!
- Carry out the service, maintenance and repair work only if the
 - machine is positioned on firm and level ground
 - apply parking brake
 - all attachments have been lowered to the ground
 - stop the engine
 - ignition key is removed
 - machine has been secured against unintentional movement !
- If carrying out repair or maintenance work with the engine running:
 - Only works in groups of two
 - Both must be authorized for the operation of the machine
 - One person must be seated on the seat and maintain visual contact with the other person
 - Comply with the safe instructions in the operator's manual
 - Keep a safe distance from all rotating and moving parts, e.g. fan blades, V-belt drives, PTO shaft drives, fans etc.!
- Before carrying out assembly work on the machine, make sure no movable parts will roll away or start moving!
- To avoid the risk of accidents, parts and large assemblies being moved must be carefully attached and secured to lifting gear. Use only suitable lifting gear in a perfect state with adequate load-bearing capacity!
Keep away from the suspended components.
- **The brake and steering systems are crucial to safety. Maintenance work must be carried out by trained staff and an authorized work workshop only!**

Safety instructions

- Have loads fastened and crane operators instructed by experienced persons only!
- Always use specially designed or otherwise safety-oriented ladders and working platforms to carry out overhead assembly work.
 - Never use machine parts or attachments as a climbing aid!
- Clean connections and threaded unions, of any traces of oil!
 - Do not use aggressive detergents!
 - Use lint-free cleaning rags!
- Before cleaning the machine with water, steam jet (high-pressure cleaner) or detergents :
 - because of safety and functional reasons, water, steam jet or detergents must be prohibited from being inside.
 - After cleaning, remove all covers and tapes applied for that purpose !
- After cleaning, check all fuel, lubricant and hydraulic oil lines for leaks, chafe marks and damages.
- Check and tighten all loosed screws!
- Any safety devices removed for maintenance or repair purposes must be refitted and installed immediately upon completion of the maintenance and repair work !
- Make sure all consumables and replaced parts are disposed of safely and with minimum environmental impact !
- Do not use the load units as lifting platforms for persons !
- Before working with some parts which are dangerous for people's life and limb (bruising, cutting), always ensure safe blocking of these areas !
- Carry out maintenance for a raised machine, attachments, make sure movable parts have been safely locked!
- Avoid contact with hot parts, such as the engine block or the exhaust system during the operation of the machine and for sometime afterwards, because it will be dangerous !
- When knocking pins strongly, they will fly out or break out, which will lead to danger of personal injury !
- Do not use starting fuel! When preheating at the same time, it will cause danger of explosions !
- Apply special care when working on the fuel system, because this will increase danger of fire !

2.6 Maintenance work on protective ROPS and FOPS structures

Canopy, roll-over bars

- Straightening and welding work on canopies, roll-over bars are prohibited. These structures must be replaced by original spare parts from the manufacturer!
- Drilling or modifying ROPS/FOPS structures are prohibited!
- Driving or working with the wheel loader without installing the protective ROPS/FOPS structures correctly is prohibited!

2.7 Warning of special hazards

Electric energy

- Use only the fuses with the specified current rating !
If there are troubles that occur in the electric system, switch off the machine immediately and rectify and malfunction !
- When working with the machine, maintain a safe distance from overhead electric lines !
If work must be carried out close to overhead lines, the equipments must be kept away from them.
- If you machine comes into contact with a live wire :
 - Do not leave the machine.
 - Drive the machine out of the danger area
 - Warn others against approaching and touching the machine.
 - Cut off the live wire battery.
 - Do not leave the machine until the line that has been touched or damaged has been safely de-energized!
- Work on the electrical system may only be carried out by a technician with appropriate training in accordance with the applicable electrical engineering rules !
- Inspect and check the electrical system regularly, defect such as loose connections or scorched cables must be rectified immediately !
- Keep eye on the operating voltage of the machine/attachments !
- Remove the earthing strap from the battery when working on the electrical system or when carrying out the welding work.
- It is dangerous to use the external battery jumper start if operation is improperly !

Gas, dust, steam , smoke

- Operate the machine only on adequately ventilated premises ! Please make sure there is sufficient ventilation before starting internal combustion engines or operating fuel-operated heating systems on enclosed premises !
- Observe the regulations in force at the respective site !
- Carry out welding, flame-cutting and grinding work on the machine only if this has been expressly authorized. There can be a risk of explosion and fire !
- Before carrying out welding, flame-cutting and grinding work on the machine, clean machines and surrounding dust, also other inflammable substances, make sure the premises are adequately ventilated-danger of explosions !

Hydraulic

- Work on the hydraulic equipment of the machine must be carried out by persons having special knowledge and experience in hydraulic systems !
- Check all lines, hoses and screwed connections regularly for leaks and obvious damage. Repair any damage and leaks immediately ! Splashed oil can cause injury and Pre!
- In accordance with the Operator's Manual/instructions for the respective assembly, release the pressure in all system sections and pressure lines (hydraulic system) to be opened before carrying out any implementing/repair work !
- Hydraulic lines must be installed laid correctly, the fittings, lengths and quality of the hoses must comply with the technical requirements !

Noise

- Wear ear protectors if necessary !

Oil, grease and other chemical substances

- When handling oil, grease and other chemical substances (e.g. battery electrolyte-sulphuric acid), observe the product-related safety regulations !
- Be careful when handling hot consumables - risks of burning or scalding !

Battery

- When handling the battery, comply with the specific safety instructions and regulations relevant to accident prevention. Batteries contain sulphuric acid-caustic !
- When charging batteries, and during normal operation of batteries, an oxyhydrogen mixture is formed in the battery cells, danger of explosion !
- In the case of a frozen battery or of an insufficient electrolyte level, do not try start-up with a battery jump cable. The battery can burst or explode !

Tyres

- Repair work on tyres and rims must be carried out by technical staff by an authorized workshop only !
- Damaged tyres and/or wrong tyre pressure reduce the operational safety of the machine. Therefore regular checks are necessary.
- Do not inflate tyres with inflammable gas-danger of explosion !
- Check the wheel nuts once a day for tightness.
- After changing wheels, retighten the wheel nuts after 10 service hours !

Note:

3 Operation

3.1 Description of control elements

This chapter describes the controls in the cab, and the function and operation. We will illustrate when machine controls or other components are installed as optional.

3.2 Driving position overview

Driving position (overview)

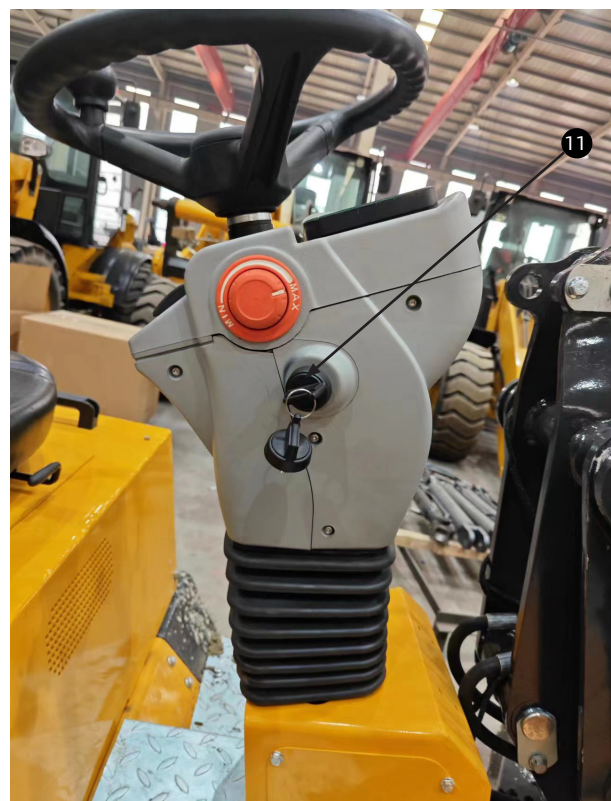

Item	Description
1	Headlight
2	Throttle pedal
3	Braking pedal
4	Safety belt
5	Multifunctional joystick
6	Manual storage box
7	Brake + Contour light + Steering tricolor lights
8	Front working light
9	Rotating alarming signal light
10	Rear working light
11	Ignition switch
12	Steering column angle adjustment locking joystick

3.3 Dash board, switch combination, joystick (overview)

Multifunctional touching screen dash board



Main interface-Style 1:

- This interface is the default startup screen.
- This interface showed important parameters of this loader.
- Swipe your finger down from the top of the interface, then you can reach the next interface:

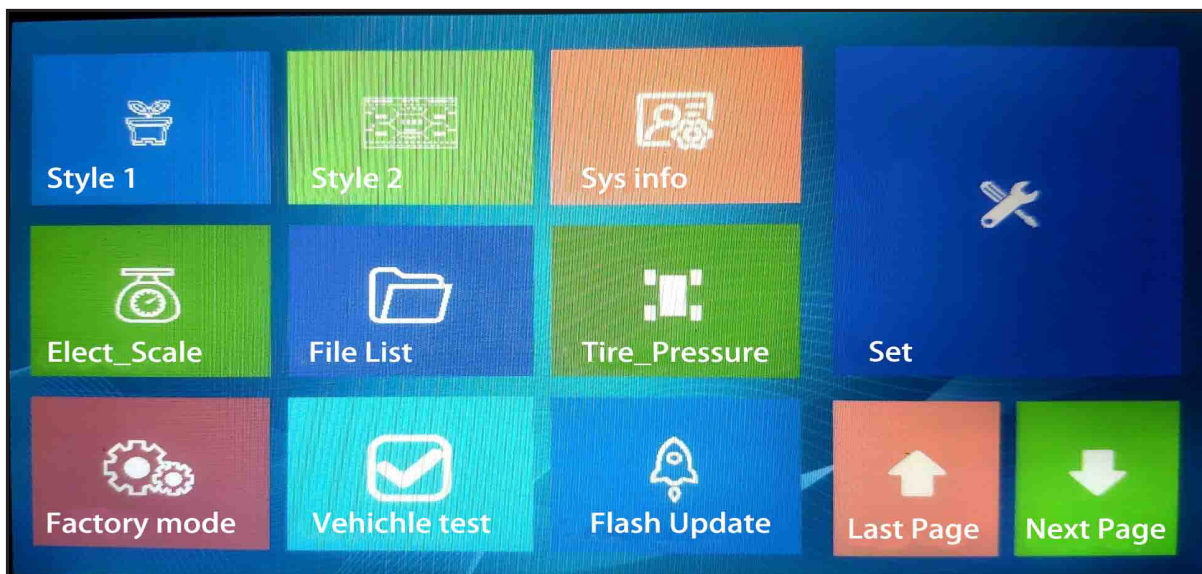

Next we will introduce some important functions on this interface

Operation

Main interface-Style 2:

- Click Style 2 in the function interface, then enter this interface
- This interface also shows important parameters of this loader
- You can switch different styles according to personal preference

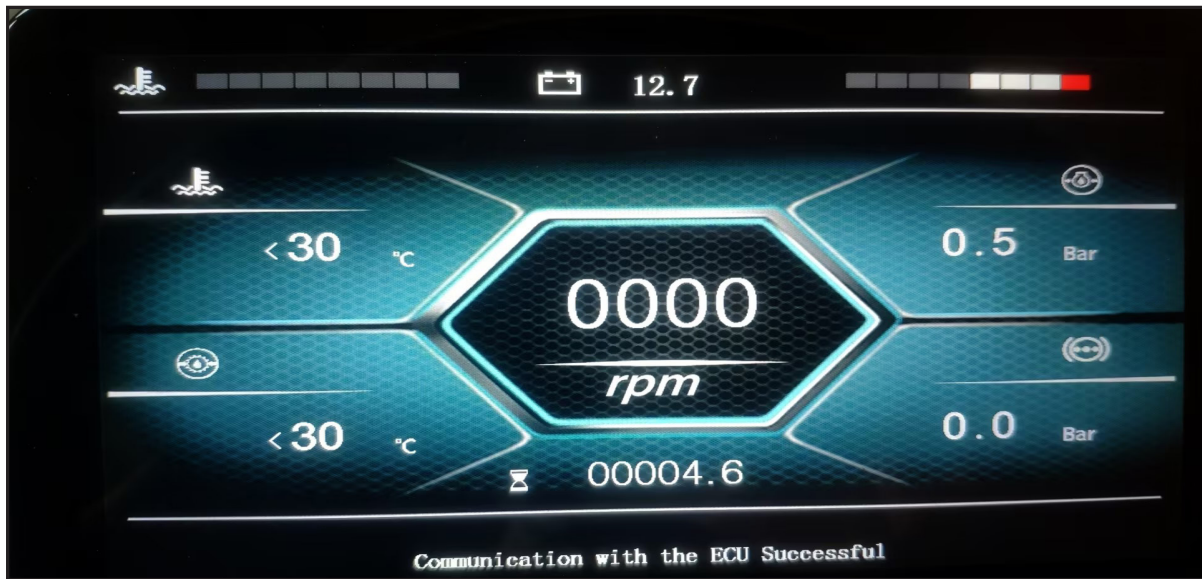

System information interface:

- Click "Sys info" to enter into this interface
- This interface shows some important real-time parameters in details:

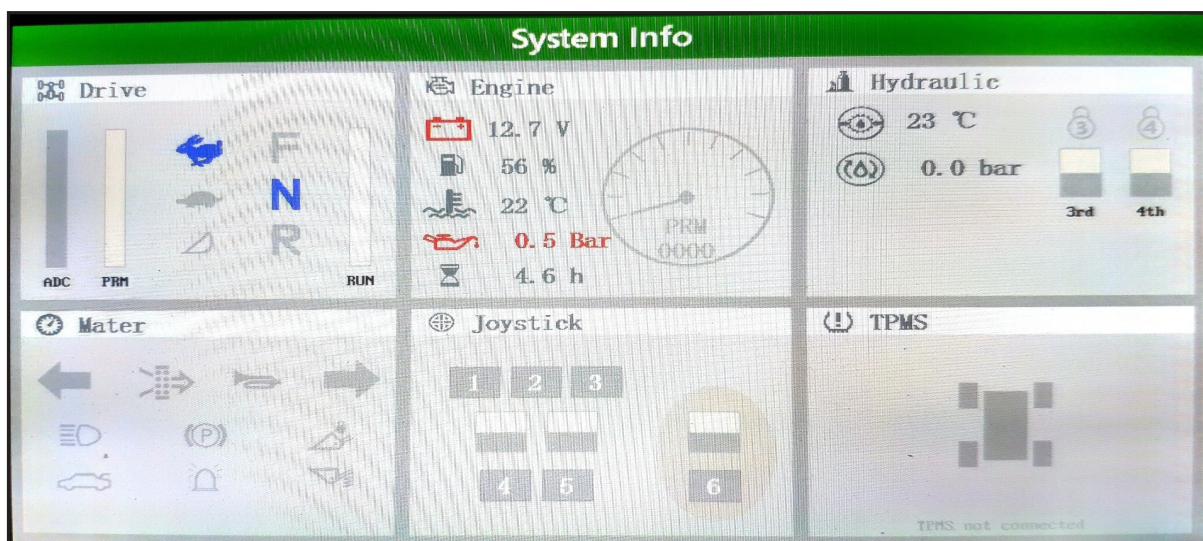

Vehicle test interface:

- Click "Vehicle test" in the function interface and enter it
- This interface can be operated, and normally used scenario is :
 - Test if the machine can work normally, such as exclusive method, if the end control element fails, but electrical controller is in good condition, then the ICONS on this interface can control the machine
 - When meeting the end control element fails (like joystick), but electrical controller is in good condition, you can use this interface to temporarily operate the machine away from the work area.

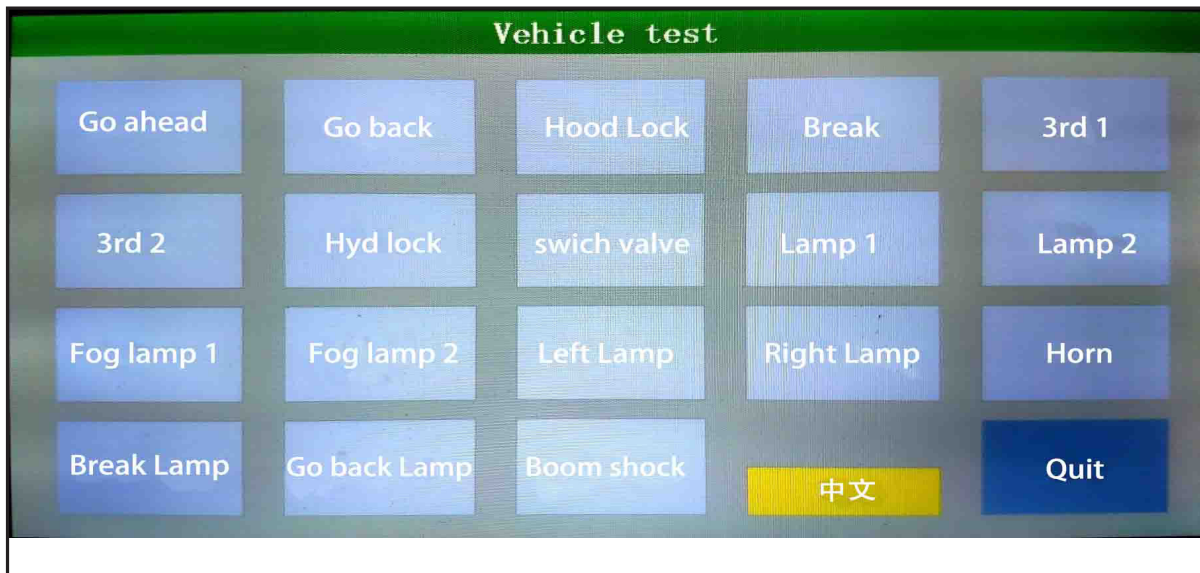

Factory mode interface:

- Click "factory mode" in the function interface and enter it
- This interface is used for factory debugging or troubleshooting by professional users. A password is required to enter it. Please consult your dealer

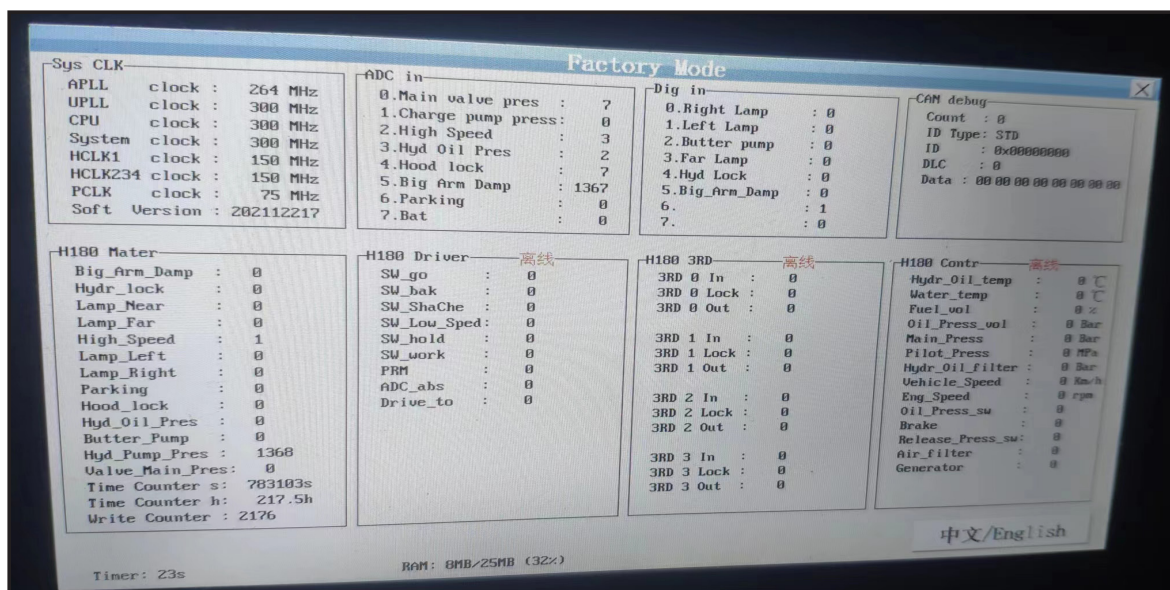

Operation

Switch combination

Switch combination is located on the dashboard under the steering wheel



•Switch of headlight



•Switch of the left turning light

•Switch of the right turning light



•Parking brake switch

•Rotating warning light switch

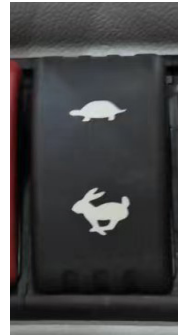

•Low speed switch

•High speed switch



•Quick hitch safety switch

•Load stabilizer switch



•Engine intake preheating switch

•Honking horn

Ignition switch and cruise control are located on the right of the dash board.



- Cruise control
- Ignition switch

Operation

Emergency stop switch is located on the left of the dash board.



•Emergency stop switch

Joystick of the loading unit



•Horn



•Locking 3rd control circuit output flow(option)



•Locking 4th control circuit output flow (option)



Left thumb wheel
•select driving direction



Right thumb wheel
•Locking/unlocking the attachment or control it 3rd hydraulic circuit



•Set neutre



•Choose high



Back thumb wheel

•Control 4th hydraulic circuit flow output (optional, stemless regulation)



•Loading model (press this when loading can provide larger driving strength)

3.4 Use wheel loader

Safety instructions on testing

- Only use steps and handles when getting on and off
- Face the machine when getting on and off
- Do not use the controller or movable cables and wires as handles
- Keep foot pads and handles clean, make sure it is always held securely.
- Clean any dirt immediately, such as oil, grease, soil, snow or ice
- Do not get on or off when operation the machine, never jump down from the machine!
- Before leaving the wheel loader, turn down the diesel engine and apply the parking brake.
- Always comply with warnings and information label and the ultimate load of the machine

Operator's important information

- Operator (driver) must read and understand this manual before operating the machine.
- Only authorized persons can use this loader
- Only operate the machine when the operator is seated.
- Do not carry or transport accompanying persons in the cab or on the wheel loader
- Only apply with the machine in accordance with the specific use and when its technical things is in a good state, figures and the manuals are provided only by persons who fully understand the risks involved in operating the machines.

The run-in period of wheel loaders

Operate the machine carefully for the first 100 hours of operation.

There are some suggestions as follow:

- Do not overload the machine, but at the same time do not drive so cautiously, because machines will never reach its suitable working temperature.
- Do not run the engine at high speed for long periods of time.
- Gradually increase the load while changing the engine speed.
- Never allow the engine to idle for long periods of time
- Comply with the maintenance plans strictly and implement (or have implemented) specified maintenance work

3.5 Checklist

This checklist does not contain all malfunction contents, this is merely intended as an aid for you.

If the answer to one of the following questions is NO, first rectify the cause of the fault before starting or continuing work.

Starting checklist

Check the following points before putting the machine into service or starting the engine

No	Starting checklist	√
1	Enough fuel in the tank?	
2	Engine oil level OK?	
3	Oil level in hydraulic tank OK?	
4	V-belt condition and tension checked?	
5	Loader unit lubricated?	
6	Brake system (including parking brake) OK?	
7	Tyre condition and inflation pressure OK?	
8	Wheel nuts safely tightened (especially after a wheel change)?	
9	Lights, signals, indicators, warning lights and signal lights OK?	
10	Lights, steps and floors clean?	
11	Attachment on the loader unit safely locked?	
12	Engine cover safely locked?	
13	Especially after cleaning, maintenance or repair work: Rags, tools and other loose objects removed?	
14	Approved warning triangle, hazard warning light and first aid kit in the machine?	
15	Seat position and rear view mirrors correctly adjusted?	
16	Seat belt fastened?	

Operation checklist

After starting the engine and during operation, check and observe the following points:

No.	Operation checklist	√
1	Engine oil pressure and alternate generator Ok?	
2	Braking effect sufficient?	
3	Engine coolant normal?	
4	Steering system working properly?	
5	Anyone dangerously close to the machine?	
6	Attachment is locked safely?	
When driving on public roads, particular attention should be paid to the following points:		
7	Bucket and attachments in lower position?	
9	Load unit joystick has been hidden, is this easy to be touched?	
10	Front-edge protection fitted to bucket?	

Packing checklist

Check and observe the following points when parking the machine:

No.	Packing checklist	√
1	Attachments on the loader unit lowered to the ground?	
2	Parking brake applied?	
3	Diesel engine stopped?	
4	The driver barrier is locked?	
When parking on public roads :		
5	Steering system working properly>	
When parking on slopes :		
6	Machine additionally secure with chocks under the wheels to prevent it from rolling away?	

3.6 Engine cover lock

Opening/cloaking the engine

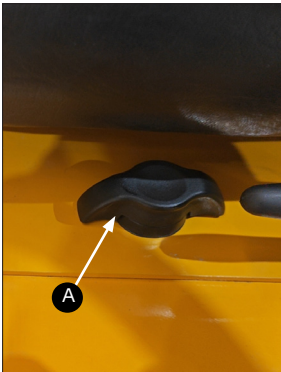

Danger !

Be careful, there are high-speed rotating parts in the cabin!

☞ The engine must be turned off before opening the engine hood.

☞ Open the engine hood:

- Stop the engine, remove the ignition key and get out of the car
- Rotate A to the right and the engine hood opens
- Pull up the hood

☞ Close and lock the engine hood:

- Pull down the engine hood,
- Rotate A to the left means the engine cover has been locked.

3.7 Diesel oil level sensor



The diesel oil level sensor is located on the front frame cover.

3.8 Putting the diesel engine into operation.

Preparing to start the engine



Danger !

The wheel loader may be put into service only if the operator is seated on the seat !

☞ Operate the machine from the seat only

☞ Prepare to start the engine as follows :

- Run through the "Start-up" checklist
- Adjust seat position
- All controls must be within easy reach
- You must be able to move the brake and accelerator pedals to their limit positions
- Fasten your seat belt
- Make sure to use the parking brake



Important !

If the engine will not start, please pay attention :

- Do not run the starter for more than 10 seconds
- Wait about 1 minute so the battery can recover before trying again
- Do not start the machine by towing, as this will damage the machine.

When working at outside temperatures of less than -15 degrees Celsius for extended periods, we recommend you that retrofitting the machine with an oil and fuel preheater.

Starting the engine

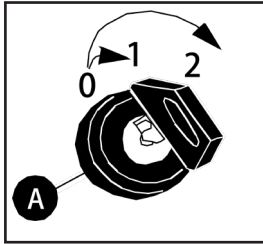

The ignition lock is located on the dash board under the steering wheel

☞ Turn the ignition key to position "1":

- If the battery is alive, then the machine is charged, and can use automotive electrical appliances.
- Multifunctional touch screen dash board starts, and enters into the default interface

☞ Turn the ignition key to position "2" and continually rotate this to start the engine:

- If the battery is charged enough, the engine will start.
- Multifunctional touch screen dash board can show real-time parameters of the machine

☞ When starting in low temperature, please use the engine intake preheating assists the engine starting:

- Press the intake preheating switch 10-30 seconds, heat the air for the engine.
- Start the engine

Avoid running the engine under low-load conditions



Caution! !

If the engine is running at high speed and its load is less than 20%, its performance will be affected negatively

Operating temperature is not reached:

- Increase the consumption of lube oil
- Lube oil in exhaust system,
- Engine contamination
- Blue smoke in exhaust

We recommend that running the engine at loads of over 20% during regular operation

Stopping the engine

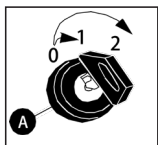

Caution! !

In order to avoid heat accumulation and damage to the exhaust gas turbo-charger, do not stop the engine from full throttle !

☞ Let the engine run at idling speed for about 2 minutes and then switch it off

☞ Apply the parking brake

☞ Turn the ignition key to "0" and remove it



Caution!

In order to avoid the short supply of lubricating oil to damage the

☞ Do not run at full speed when the cold machine starts

☞ Preheat the engine at idling speed about 30 seconds

3.9 Jump-starting the engine (external battery)

Safety instructions regarding external battery starting the engine



Caution! !

The jump lead connected to the position (+) terminal of the starting battery

Never connect with electrically conductive vehicle parts-danger of short circuit !

☞ The external power source must be 12V, higher supply voltages will damage the electrical system of the vehicles !

☞ Use only authorized jump leads which conform to the safety requirements and which are in perfect condition !

☞ Route the jump leads so they cannot catch on rotating components in the engine compartment !

Providing external starting aid

☞ Proceed as follows:

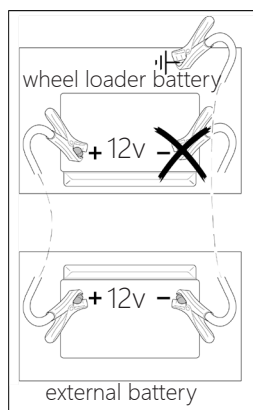

•Drive the assisting vehicle close enough to the wheel loader so that the jump leads can reach to connect the two batteries

•Start the engine of the vehicle

•First connect the end of the red jump lead (+) to the +terminal of the loader battery, then connect the other end to the +terminal of the auxiliary battery

•Connect the end of the black jump lead (-) to the terminal of the auxiliary battery

•Connect the other end of the black jump lead (-) onto a solid metal component firmly mounted on the engine block or onto the engine block itself ! Do not connect it to the negative terminal of the loader battery, otherwise explosive gas emerging from the battery can ignite if sparks are formed

•Start the engine of the machine

After starting the engine:

•With the engine running, disconnect both jump leads in exactly the reverse order (first remove the -terminal, then the + terminal), this prevents sparking in the vicinity of the battery!

3.10 Steering system

Steering column angle adjustment



Danger !

In order to avoid danger of accidents, do not adjust the steering column when driving !

☞ Adjust the steering column at machine standstill as follows:

•Stop the engine and remove the ignition key

•Apply the parking brake

•Sit down on the seat, and release the steering column adjustment handle

•Adjust the inclination of the steering column to your requirements

Tighten the adjustment

Check the steering system

☞ Functional check of steering system
With the engine running, turn the steering wheel to the left and right



Important !

The machine can still be steered if the diesel engine or the pump drive breaks down !
But this needs bigger power! Please make sure you understand the risks!

3.11 Accelerator pedal

Speed control with the accelerator pedal



☞ Use the accelerator pedal to control the driving speed:

- Accelerator is located on the right
- Press the accelerator pedal down
 - ➔ Drive speed is increased
- Release the accelerator pedal slowly
 - ➔ Drive speed is low
- Release the accelerator pedal completely
 - ➔ Hydrostatic braking



Important !

Maximum speed depends on the speed range selected.

3.12 Braking pedal

Specific information on brake pedal



- Brake pedal is located on the left of the machine.
- Dirt accumulation and objects in the area of the braking pedal can result in brake malfunctions.
- Keep the brake pedal clean and remove all objects in the area of the pedal



Danger !

When running the machine, use the parking brake in case of emergency !

☞ Press the pedal down with force in order to break the machine

Braking with the brake pedal



- ☞ Before braking, check that no-one will be hindered
- ☞ Release the accelerator pedal fully and press the brake pedal down with force
 - ➔ The rear red braking light will come on at the rear of the vehicle.
 - ➔ The reverse buzzer will sound a high frequency warning tone.
 - ➔ The machine is braked to a standstill regardless of the position of the forwards-reverse control on the joystick

Caution when stopping on slopes:

- ☞ Press brake pedal down with force until the braking effect is felt.



Caution !

When driving down will, use the brake pedal to support the braking effect of the drive. This avoids damage to the drive and /or the diesel engine!

3.13 Parking brake

General instructions regarding the parking brake

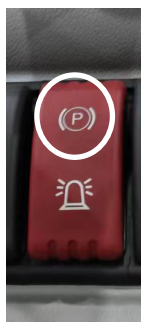

The parking brake key is located under the steering wheel.

Applying the parking brake

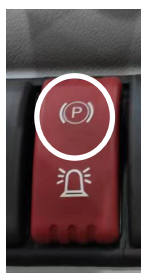

Danger!

When driving the machine, apply the parking brake only in an emergency !

- ☞ In normal operation use only the brake pedal as a service brake



☞ Apply the parking brake

- Press parking brake key down
- The parking icon on the meter lights up.
- Secure the machine with wheel chocks

☞ Release the parking brake

- Remove wheel chocks
- Release parking brake key
- The parking icon on the meter goes out.

3.14 Driving the machine

Selecting a speed range

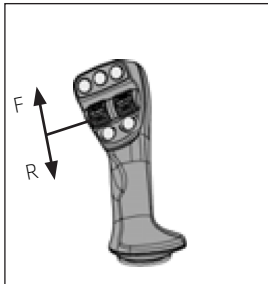

The machine has two speed ranges. The switch for selecting the speed range is located on the switch combination under the steering wheel.

☞ **Select the 1st speed range** 🐢

- Press switch to position 1
- Select the driving direction with left thumb wheel (F or R) ☞ **Select the**

2nd speed range 🐰

- Press switch to position 2
 - Select the driving direction with left thumb wheel (F or R)
 - Gradually press down the accelerator pedal
- ☞ Machine moves off
- Test brakes at low speed



Speed range symbol	Speed range	Recommended
	Lower speed	Used for work involving short loading cycles, a rapid succession of loading and unloading operations, such as on a truck, and for work requiring precise speed adjustment, such as using sweeper
	Higher speed	Long distance traveling

Changing directions(forward/backward)

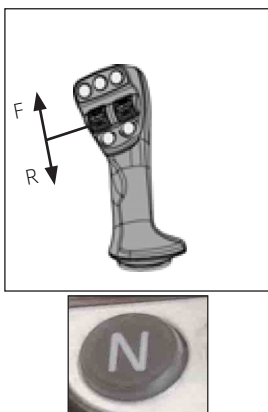

Important !

Do not change direction when the machine drives in high speed! It is possible if driving speed is less than 15km/h.

☞ **Changing driving direction**

- Reduce engine speed: remove your foot from the accelerator pedal
- Slow down your drive speed to less than 15km/h
- Changing direction by using left thumb wheel (F/R), or using N button to hang into neutral.
- Apply the parking brake at machine standstill



Driving direction	Operation	Telltale on instrument panel
Forwards	Press left thumb wheel forwards F	F lights up
Backwards	Press left thumb wheel backwards R	R lights up
Neutral	Press button N down	N lights up

3.15 Cruise control

Using the cruise control

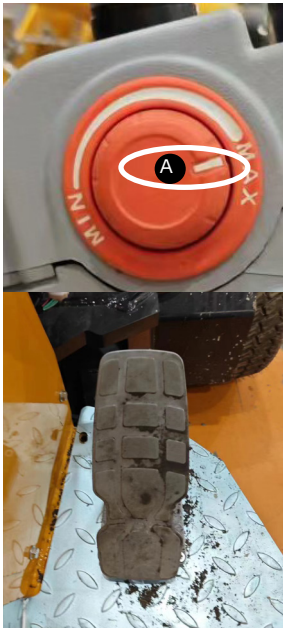

This function is useful for hydraulic driving attachments (such as sweeper, and snow ploughing). It also can achieve step less adjustment and constant driving speed.

Driving speed is set through the cruise control potentiometer, and is Holden with the accelerator pedal.

☞ Using cruise control:

- Rotate the cruise potentiometer to the desired speed
- Press the accelerator pedal down the deepest position and then you can get the setting driving speed.

3.16 Headlights and working lights

Operation on headlights and working lights



The switches of the lights are located on the switch combination under the steering wheel.

☞ Apply the lights:

- Press the switch of the lights down
- Telltales on the dash board lights up
- Headlights goes on
- Four front and rear working lights on the canopy light up (option)

3.17 Signal lights and emergency stop switch



Turning indicator operation



Left

Right

Function		Telltale
Left	Press down, left turning indicator lights	Left arrow flashes
Right	Press down, right turning indicator lights	Right arrow flashes

Left	Right
	

Rotating warning signal lights operation

Function	
Key 1	Press down, the warning light flashes

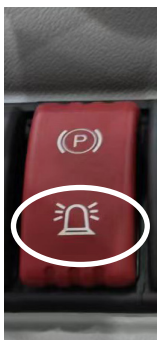

Emergency stop switch



Important !

Use this switch only when meeting emergency condition ! Please reset immediately after use!

- ☞ Use emergency stop switch:
 - Press the emergency stop switch down with force
 - Machine stops working
- ☞ Reset the emergency stop switch:
 - Rotate the EMERGENCY switch in the direction of the arrow
 - Reset the switch

3.18 Seat

Horizontal adjustment

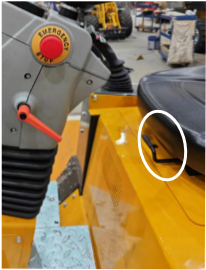

☞ Adjust the front and rear position of the seat:

- Sit on the seat
- Pull the bar upwards
- Move to the suitable position forwards and backwards
- Release the bar

Backrest adjustment



☞ Adjusting the backrest:

- Sit down on the seat
- Pull the lever
- Lean back to push the backrest into the required position
- Release the lever

3.19 Seat belt

Specific instructions regarding the seat belt

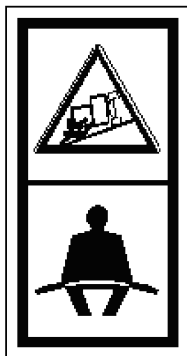

Danger!

In order to avoid injuries, fasten the seat belt when driving the wheel loader

☞ Bear in mind the following when fastening the seat belt:

- The seat belt must not be twisted !
 - Seat belt must run over the hips-not over the stomach-and must always be applied tightly !
 - Do not place the seat belt over hard, edged or fragile items (tools, meter rule, glasses, pen) carried inside your clothes.
 - Never buckle up several persons !
 - Check the condition of the seat belt regularly. Have damaged seat belts immediately replaced by an authorized workshop !
 - Keep the seat belts clean, as coarse dirt can impair proper functioning. !
 - After an accident the belt strap is stretched and must be replaced by a new one by an authorized workshop !
-

Fastening the seat belt

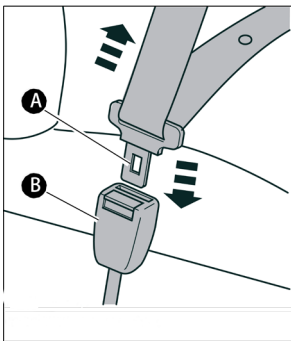

- ☞ Fasten the seat belt as follows after getting on the machine:
- Hold the belt at buckle latch A and run it slowly and steadily over the hips
 - Insert buckle latch A into buckle latch B until it engages audibly
 - Tighten the seat belt by pulling at its end
 - ☞ The seat belt must always be tightly in place over the hips !

Unfasten the seat belt

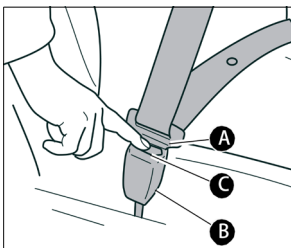

- ☞ Unfasten the seat belt as follows:
- Press red button C on buckle B
 - ☞ Latch A is released from buckle B by spring action

Longer/shorter lap belt adjustment

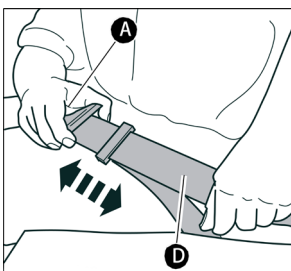

- ☞ Lengthen the lap belt as follows:
- Hold buckle latch A at a right angle to the seat belt and pull the seat belt to the required length
 - To shorten the lap belt, just pull the free end D of the belt

3.20 Do not tow the machine

Never tow the machine

The hydrostatic transmission system applied on this machine does not allow any towing methods. If the machine malfunctions and cannot be moved, please use the crane to lift it onto a transport vehicle and leave.



Caution!

If using towing ways to move the machine formerly, then the machine will be permanently and irreversibly damaged !

☞ Never use any towing ways to move the machine !

3.21 Decommissioning the machine temporarily

Parking/stopping the machine



Danger!

Machines parked on slopes can roll away.

- ☞ Use the parking brake to park the machine safely.
- ☞ Additionally secure the machine by placing chocks under the downhill sides of the wheels !
 - Wheel chocks are put on the left of the front frame (near the left headlight)

☞ To decommission the machine temporarily, proceed as follows:

- Reduce engine speed: remove you foot from the accelerator pedal
- Stop the machine with the parking brake
- Move the machine to neutral with tip switch on the joystick
- Apply the parking brake
- Lower the load unit
- Place the bucket on the ground so that the edge is flat with the ground.



Caution!

After engine operation under full load:

- ☞ Allow the engine to idle for a period of time to gradually reduce the temperature

- Stop the engine and remove the ignition key
- When leaving the seat, close the driver barrier (if have)
- Close and lock the engine cover
- Close and lock the radiator cover

On slopes:

- Additionally secure the machine by placing chocks under the downhill sides of the wheel !
 - Wheel chocks are fastened on the left of the front frame (near the left headlight)**

Decommissioning the machine for a longer time

- If possible, retract the piston rods of the hydraulic cylinder to protect them against damage.
- Protect the exposed part of the piston rods from corrosion.
- Before putting the machine into operation again, clean the piston rods, never use a grease solvent or a high-pressure cleaner, because water can penetrate into it , and cause corrosion and damage to the piston rod.

3.22 Loading and transporting the machine on a vehicle

Safety instructions regarding loading on a transport vehicle

- The transport vehicle must be of adequate size
- Make sure the maximum height of the transport vehicle is not exceeded.
- Remove any mud, snow or ice from the tires so that the machine can be safely driven onto the ramps
- Secure the wheel loader against unintentional movement!
- When loading, do not exceed the gross weight rating and gross axle weight rating.
- Place practical loads so as to ensure an even load on all axels.
- Store or secure the load with suitable auxiliary means so that it cannot slip, slide, roll, tip over or fall, or cause the vehicle to tip over under usual transport conditions.
- Usual transport conditions are conditions in the which the brakes are slammed on, evasive maneuvers are carried out with vehicles or in which uneven nowadays are driven on. Auxiliary means are e.g. anti-slip bases and linings, load-securing straps and chains, clamping beams, protective paddings, nets, edge protectors, etc.
- You should select suitable driving speed and operating ways depending on the loading weight and road conditions.

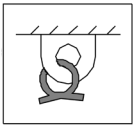

Caution !

When loading and driving on slopes, the diesel engine can be damaged if the engine oil level is too low.

☞ Lubricating oil level of the engine must meet requirements.

Loading and tying down the machine

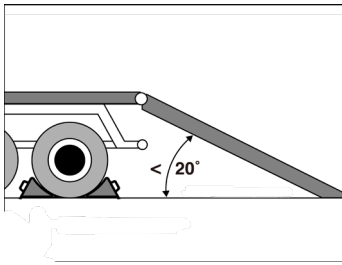

☞ Load as follows:

- Secure the transport vehicle with chocks to prevent it from rolling
- Place the access ramps at the smallest possible angle
- Do not exceed an angle of 20 degrees
- Use access ramps with an anti skid surface only
- Make sure the area is clear and not obstructed
- Make sure the access ramps and the wheels of the machine are free of oil, grease and ice.
- Check the engine oil level
- Start the engine of the machine
- Raise the loader unit enough so that it will not touch the access ramps
- Carefully drive the machine onto the middle of the transport vehicle
- Set the drive to neutral
- Lower the loader unit (bucket) to the loading area of the transport vehicle
- Stop the engine
- Apply the parking brake
- Remove the ignition key
- Do not allow anyone to stay on the seat, and close the driver barrier and engine cover.

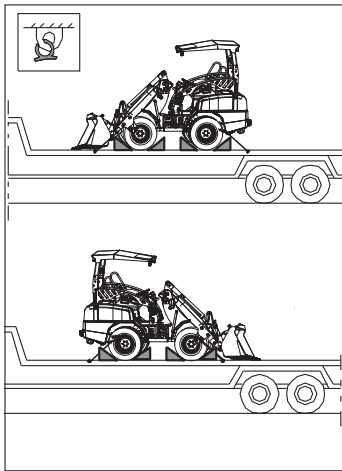

☞ Tie down the machine as follows:

- Firmly tie down the machine at the eye hooks with sufficiently dimensioned belts or chains onto the platform. If possible, secure the wheels with additional chocks at the front, rear and at the sides.
- Before transporting the machine through heavy rain: close the outlet of the exhaust silencer with a simple cap or suitable adhesive tape
- Make sure the driver of the transport vehicle knows the overall height, width, and weight of his vehicle (including the load), and the legal transport regulations of the country or countries in which transport will take place!

3.23 Loader unit control lever (overview)

Control lever (joystick) for lift and tilt arms and 3rd and 4th hydraulic control circuit

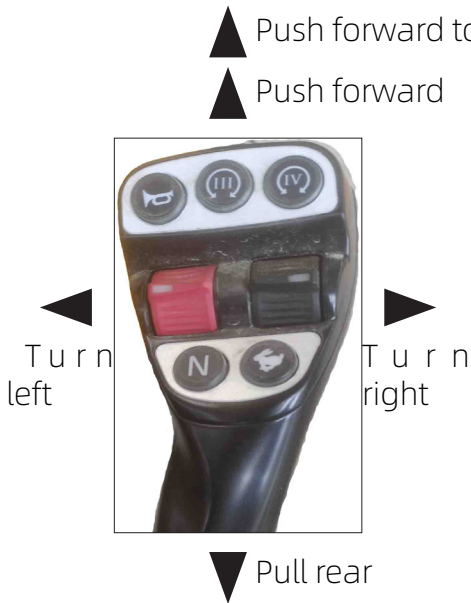

Operation	Function
Forwards	Lower the loader unit
Fully forwards	Lower the loader unit to Boat position
Backwards	Raises the loader unit
To the left	Tilt upwards and lift materials
To the right	Dumps out the materials



Important !

There is a float position on the control valve. This is beneficial when working with the sweeper or snowplough !



•Horn



•Locking 3rd control circuit output flow(option)



•Locking 4th control circuit output flow (option)



Left thumb wheel
•select driving direction



Right thumb wheel
•Locking/unlocking the attachment or control it 3rd hydraulic circuit



•Set neutre



•Choose high



Back thumb wheel
•Control 4th hydraulic circuit flow output (optional, stemless regulation)



•Loading model (press this when loading can provide larger driving strength)

3.24 Operation of the 3rd control circuit



Important !

There are two operations for 3rd control circuit:

- Locking/unlocking the attachment on the quick change
- The running of the hydraulic attachments

These two functions can be switched with a compulsory self-resetting switch.

Locking/unlocking attachments on the quick change



Unlocking switch (3rd control circuit)	Result
Press the switch A by left hand	Safety switch, self-resetting feature, must press to lock or unlock attachments
Lock attachments on the quick change	Result
Press switch A by left hand, pull right thumb wheel B forwards	Lock pin stretches out, attachments are locked
Unlock attachments on the quick change	Result
Press switch A by left hand, pull right thumb wheel B backwards	Lock pin stretches back, attachments are unlocked
Lock the hydraulic circuit	Result
Release switch A	Right thumb wheel B doesn't work for quick change, can work safely



Important !

Regrading how to connect attachments:

- With reference to P3-P41- multifunctional bucket connection

Operation of hydraulic attachments



Attachments operation	Result
Push right thumb wheel B forwards	Add pressure or open the hydraulic attachment A (function) or P (oil-taking)
Pull right thumb wheel B backwards	Add pressure or close the hydraulic attachment B (function) or P (oil-taking)

3.25 Continuous output of the 3rd control circuit

Continuous output of the 3rd control circuit



Work for a longer period of time to output the flow or hydraulic driving attachments (e.g. sweeper), use right thumb wheel B achieves step less adjustment of output flow.

Continuous output of the 3rd control circuit	Result
Push right thumb wheel B forwards backwards to required output flow, and press button III at the same time, then can release right hand wheel B	The 3rd control circuit continuously output the setting flow, and does not need hold the thumb wheel position.
Cancel continuous output	Result
In the condition of continuous output, push right thumb wheel B casually.	3rd continuous output is canceled, needs push right thumb wheel B again to do output.

3.26 4th control circuit(option)

4th hydraulic return oil is used to operate the hydraulic attachments with additional functions (e.g. high dump bucket with clamps)

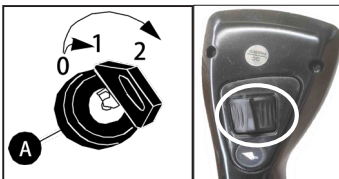

Important !

Although the engine does not run, the hydraulic system is still under pressure, so it is impossible to reconnect the attachments.

Before installing or removing attachments, release the pressure in the system and hydraulic line:

- Make sure the engine has stopped, but still charged (the ignition key is in position 1)
- Flick the back dial several times.

4th hydraulic circuit connection

Connect 4th hydraulic circuit as follows



Operation of 4th hydraulic circuit



Attachment operation	Result
Push the back thumb wheel C to the left	Add pressure to the hydraulic attachment A (function) or P (oil taking) line and open them
Push the back thumb wheel C to the right	Add pressure to the hydraulic attachment B (function) or T (oil returning) line and close them

Continuous output of the 4th hydraulic circuit



The operation for long-period output flow of hydraulic driving attachments (such as snowplough) can use back thumb wheel C to achieve step less adjustment flow output.

Continuous output	Result
Push the back thumb wheel C to left or right to the required output flow, and press button IV, then release C.	4th hydraulic circuit can output setting flow continuously and does not need to hold the thumb wheel position.
Cancel the continuous output	Result
In the condition of continuous output, push the back thumb wheel C casually.	4th hydraulic circuit is canceled, you need push the back wheel C to achieve output again.

3.27 Emergency lowering of loader unit in case of diesel engine breakdown

Lowering or raising



☞ Lower the loader unit as follows:

- Make sure no-one is dangerously close to the machine
- Apply the parking brake
- Slowly push control lever forwards (direction A), until the loader unit is fully lowered
- Return control lever to neutral
- Stop the ignition switch and remove the key

☞ Raise as follows:

- Fasten lifting gear (crane) onto the loader unit
- Pull and hold the control lever backwards
- Raise the loader unit to transport position with the lifting gear
- Release control lever
- In case of diesel engine breakdown, have an authorized workshop carry out checks and repair work

3.28 Pressure relief on the quick hitch couplers



Important !

Although when the engine is not running, the hydraulic system of the machine is still pressurized. So it cannot reconnect the attachments.

•Before installing or removing the attachments, release the pressure in the hydraulic system and hydraulic lines:

☞ Release the pressure as follows:

- Apply the parking brake
- Make sure the machine stops but still powered up (ignition key is in position 1)
- Push the right thumb wheel and back thumb wheel several times
 - ➔ Pressure in hydraulic lines is released
- Close the ignition switch and remove the ignition key
- Other attachments can be installed



3.29 Equipping the machine with a standard bucket

Fitting a standard bucket onto the quickhitch



Danger !

Before starting work, make sure the attachment is safely locked onto the quick hitch by means of the lock ram !

☞ You must be able to see the lock pins on either side in the mounting

☞ Installing bucket:

- Make sure the attachment is positioned on firm and level ground
- Turn on the machine
- Push the handle to the right in order to tilt forward the quick coupler (Reference A)
- Turn off the machine
- Get down from the machine and get the workplace C
- Turn down on the two levers placed on the quick coupler, in order to raise the two hook plugs
- Get on the machine again and turn it on
- Moving carefully approach the quick coupler of the machine to the one of the attachment in order to insert the round top
- Move slowly the handle to the left, in this way the quick coupler leans backward and aligns with the quick coupler of the attachment (Ref. C)
- Switch off the machine and get down.
- Rotate upwards the two levers in this way the two plugs of the quick coupler are correctly inserted in the Ptted seats of the attachment.
- Get on the machine again and turn it on
- Lift the attachment and lean it forward moving the handle to the right to check visually the two

3.30 Working with a standard bucket

Fields of application for bucket

- The standard bucket is mainly used for digging earth, loosening, picking up, transporting and loading loose or solid materials.
- Get informed on the legal regulation of your country which may prohibit driving on public roads with a full bucket !

Safety instructions for working with the bucket

- Never drive up the edge of a pit from outside-danger of cave-in !
- Never undermine the foundations of walls-danger of collapse !
- Operation of the wheel loader by unauthorized staff is prohibited.
- When working with the machine, look out for high-voltage cables, underground cables, gas and water pipes.
- Get informed on the legal regulations of your country which may prohibit driving on public roads with a full bucket !
- Bear in mind the mandatory regulations for accident prevention



Danger !

Before starting work, make sure the attachment is safely locked onto the quick-hitch by the lock pins.

- ☞ You must be able to see the lock pins on either side of the mounting holes on the attachment !
-

Safety instructions for transporting material in a full bucket



Danger !

In order to avoid danger of accidents, do not transport loads with a raised loader unit !

Always dump in the attachment a little towards the machine, carry it as close as possible to the ground and bear in mind the required ground clearance !

If it is dumped in, the bucket is moved parallel to its initial position as the loader unit is raised ! If the bucket is unintentionally dumped in to the limit in the raised position, material can fall over the rear of the bucket!

- ☞ In the raised position, do not dump in a loaded bucket fully to the limit

- ☞ If necessary slightly readjust the bucket

- ☞ In case of a bulky load :

- Secure the load and if necessary, fit the rear of the bucket with a protection

- ☞ Make sure good visibility of the material you want to pick up and of the work and travel range
-



Danger !

In order to avoid tipping over when driving on slopes with a full bucket, dump in the bucket fully and set the loader unit to transport position !

☞ When transporting a bucket fully loaded down a steep slope



Important !

Get informed on and follow the legal regulations of your country.

Loading loose material

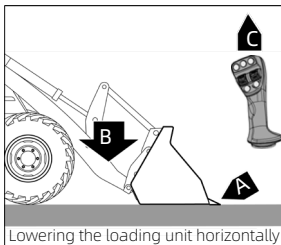

☞ Loading loose material:

- Align the blade parallel with the ground A

- Lower the loader unit to the ground B.

- Use loading model (press the button 1 at the back of the joystick), drive forwards into the material A

☞ When the engine speed decrease due to too much material:

- Slightly raise the loader unit B.

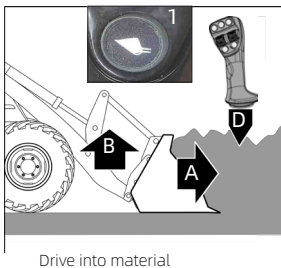

Loading if the material is hard to penetrate

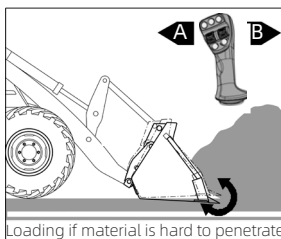

☞ Loading if material is hard to penetrate

- As for loading loose material, but in addition:

- Tilt the bucket in and out a little. To do this: move the control lever to the left and right A and B

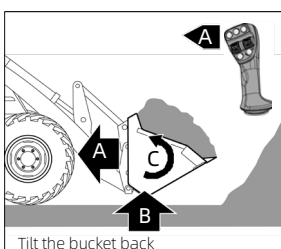

☞ Ending loading:

- Tilt the bucket back to stabilize the lifting material

- Reduce engine speed

- Reverse out of the material A

- Raise the bucket to transport position B, bear in mind the ground clearance

Removing material/digging in soft soil

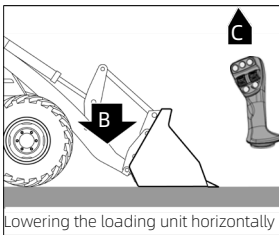

☞ Digging in soft soil

- Place the bucket horizontally on the ground B: push the control lever forwards C

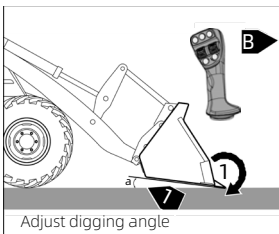

- Adjust the digging angle 1.
- Drive the machine forwards 1

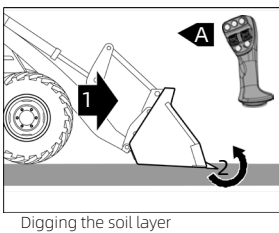

☞ Once the bucket has penetrated the soil:

- Set the digging angle a little flatter: push the control lever to the left A, so that the layer being removed is as even as possible and so that the wheel spin is reduced.
- Proceed as for loading loose material

Removing material / digging in hard soil

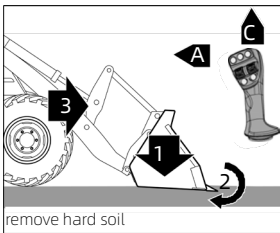

☞ Digging in hard soil

- Lower the bucket horizontally to the ground, push the control lever forwards
- Adjust the digging angle flatter than for digging in soft soil: push the control lever to the left
- Drive the machine forwards:
- Press the bucket downward a little, push the control lever forwards a little

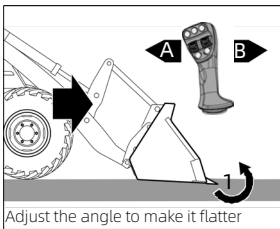

☞ Once the bucket has penetrated the soil:

- Set the digging angle a little flatter. Push the control lever to the left, so that the layer being removed is as even as possible and so that the wheel spin is reduced
- Push the control lever to the left, or move it to the left and right to loose the material
- Keep on loading material hard to penetrate

Loading heaped material (non-compacted material)

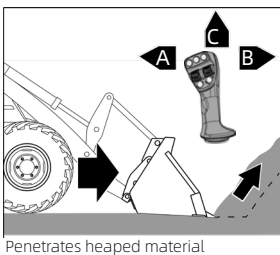

☞ Loading heaped material (non-compacted material)

- Set the blade parallel to the ground: push the control lever to the left or right
- Lower the loader unit horizontally to the ground: push the control lever forwards
- Using the loading model (press the button 1 at the back of the control lever) drive the material forwards
- After penetrating the heaped material
- Smoothly raise the loader unit and keep the bucket level

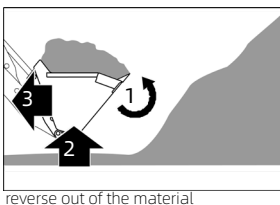

☞ When the loader unit cannot be raised further:

- Tilt in the bucket 1
- Raise the loader unit 2
- Reverse out of the material 3
- Lower the loader unit to transport position

Loading heaped material (compacted)

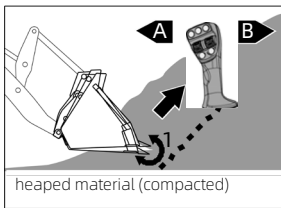

☞ Loading heaped material (compacted)

- Proceed as for non-compacted material, however when raising the loader unit through the heaped material, dump the bucket slightly in and out. Move the control lever alternately to the left and right
- Material is loosened

Grading

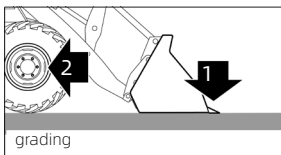

☞ After loading the material:

- Lower the loader unit horizontally to the ground (1)
- Reverse across the surface to be graded (2)

Practical hints for loading vehicles

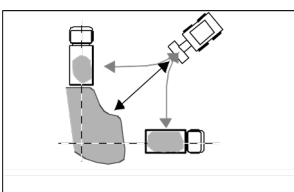

☞ Practical hints for loading vehicles

- Dump out the bucket.
- Lower the loader unit all the way
- The machine is backwards
- Reverse slowly
- Repeat this procedure until the wheels reach the ground
- Reverse the machine away

Finish work

☞ Finish work

- Dump out the bucket.
- Lower the loader unit all the way
- The machine is backwards
- Reverse slowly
- Repeat this procedure until the wheels reach the ground
- Reverse the machine away

3.31 Fitting a multipurpose bucket

Picking up a multipurpose bucket with the quickhitch



Important !

The multipurpose bucket is picked up and mounted on the quick hitch in the same ways as the standard bucket



Danger !

Before starting work, make sure the attachment is safely locked onto the quick hitch by means of the lock pin !

☞ You must be able to see the lock pins on either side of the mounting holes on the attachment!

Connecting the hydraulic lines of a multipurpose bucket to the wheel loader



Important !

The hydraulic system of the machine is still pressurized even when the engine is not running! The hydraulic quick couplers can be released, however they cannot be re-attached because the pressure in the hydraulic lines has not been released.

·Release the pressure in the sections of the system and hydraulic lines before starting setup or repair work.

☞ Proceed as follows

- Stop the engine
 - Apply the parking brake
 - Release the pressure in the hydraulic lines
 - Clean the hydraulic connections on the multipurpose bucket
 - Connect lines according to the following picture
-



Caution !

Before working, slightly test and check the multipurpose bucket for correct function



Important !

If the attachment is placed in direct sunlight after having been taken off, the oil in the hydraulic rams will warm up. This leads to a pressure increase in the hydraulic rams that will make it difficult to attach the hydraulic lines to the hydraulic connections.

Removing the multipurpose bucket from the quick hitch



Danger !

In order to prevent the attachment from tipping over, place it on the ground ensuring stability !

- Position the attachment so that after unlocking it will stand safely and not tip over



Important !

The attachment is removed from the quick hitch in the same way as the standard bucket.



☞ Remove the multipurpose bucket as follows:

- Empty the multipurpose bucket
- Stop the engine
- Apply the parking brake
- Remove the hydraulic lines of the attachment
- Close the protective caps

3.32 Working with the multipurpose bucket

Fields of application for multipurpose bucket

- The multipurpose bucket is mainly used for digging earth, and for loosening, pushing, picking up, transporting and loading loose or solid materials.
- Get informed on the legal regulations of your country which may prohibit driving on public roads with a full bucket. !

Safety instructions for working with the multipurpose bucket

- Never drive up to the edge of a pit from outside-danger of cave-in !
- Never undermine the foundations of walls- danger of collapse !
- Operation of the wheel loader by unauthorized staff is prohibited
- When working with the machine, look out for high-voltage cables, underground cables, gas and water pipes
- Get informed on the legal regulations of your country which may prohibit driving on public roads with a full bucket !
- Bear in mind the mandatory regulations for accident prevention



Danger!

Before starting work, make sure the attachment is safely locked onto the quick hitch by means of the lock ram.

☞ You must be able to see the lock pins in the mounting bores on the attachment !

Safety instructions for transporting material in a full multipurpose bucket



Danger!

In order to avoid danger of accidents, do not transport loads with a raised loader unit !

Always dump in the multipurpose bucket a little towards the machine, carry it as close as possible to the ground and bear in mind the required ground clearance !

After it is dumped in, the multipurpose bucket is moved parallel to its initial position as the loader unit is raised ! If the multipurpose bucket is unintentionally dumped in to the limit in the raised position, material can fall over the rear of the bucket!

☞ In the raised position, do not dump in a loaded multipurpose bucket to the limit.

☞ Slightly readjust the multipurpose bucket if necessary

☞ In case of a bulky load :

- Secure the load and if necessary, fit the rear of the bucket with a protection

☞ Ensure good visibility of the material you want to pick up and of the work and travel range



Danger !

In order to avoid tipping over when driving on slopes with a full bucket, dump the bucket fully and set the loader unit to transport position !

☞ Drive in reverse when transporting a bucket loaded with material down a steep slope.



Important !

Get informed on and follow the legal regulations of your country.

Grading and scraping

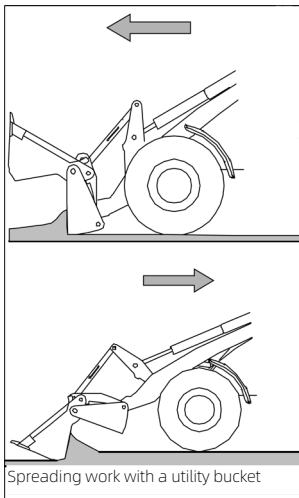

☞ Grading:

- Fold up the front half of the bucket
- Set the depth of the layer you want to remove with the lift hydraulics
- Set the angle of the rear cutting edge

☞ Drawing material backwards:

- Dump out the multipurpose bucket
- Raise the bucket with the lift hydraulics
- Fold up the front half of the bucket
- Lower the multipurpose bucket to the ground
- Set angle of the bucket
- Surfaces are graded or scraped when driving in reverse

Removing and spreading material in thin layers

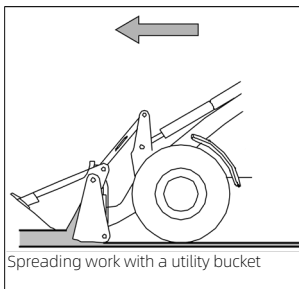

☞ Removing material in thin layers:

- Set a flat digging angle
- Fold up the front half of the bucket by about 10 to 15 cm
- Driving the machine

Material is picked up

The original position is lowered

☞ Spreading material in thin layers:

- Set the rear cutting edge parallel to the ground
- Fold up the front half of the bucket until the required material is poured onto the ground
- Drive the machine
- Lower the multipurpose bucket on the ground
- The rear cutting edge grades the material as it is emptied by opening the front half of the bucket.

Pulling out material from slopes

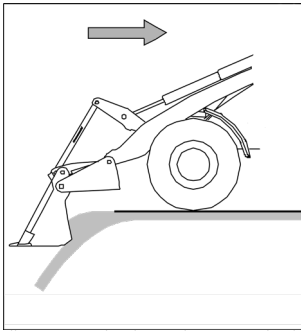

Pull out material with a multi-purpose bucket

This position allows to pull material out of slopes or roadside ditches with maximum safety and to spread it as required.

Moving material with longer reach

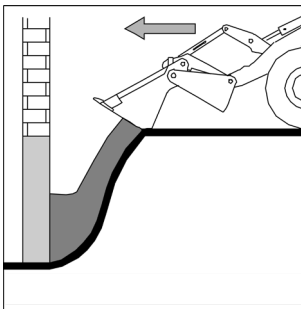

Backfilling material with a utility bucket

This position allows to move material without damaging slopes or structures.

This position allows to move material without damaging slopes or structures.

☞ Backfilling with maximum safety and without damaging slopes
Backfilling with maximum safety and without damaging slopes

Picking up remaining material completely

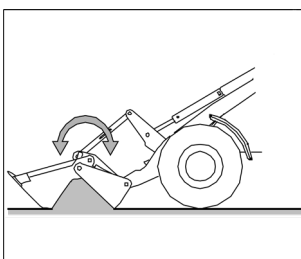

Pick up material completely with the multi-purpose bucket



Important!

Both bucket halves must touch the ground so that all the material is picked up

☞ Picking up remaining material:

- Fold up the front half of the bucket
- Dump out the bucket
- Lower the bucket to the ground, make sure both bucket halves touch the ground
- Close the multipurpose bucket, and at the same time pick up the material
- Raise the bucket with the lift hydraulics

Grabbing bulky material

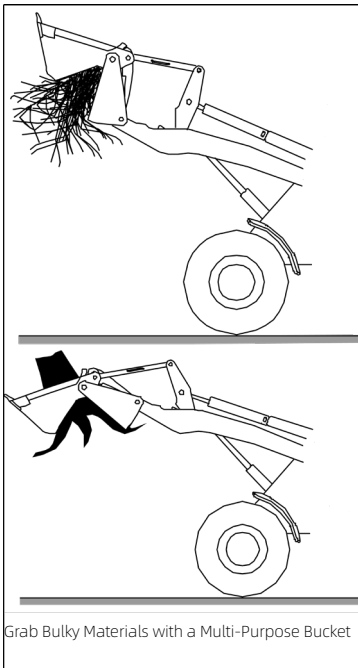

☞ Grabbing bulky material:

- The multipurpose bucket allows to safely grab, pick up and transport building timber, reinforcement bars, packaging bands, wire etc.
- The multipurpose bucket allows to safely grab, pick up and transport large objects

Pulling out and setting posts

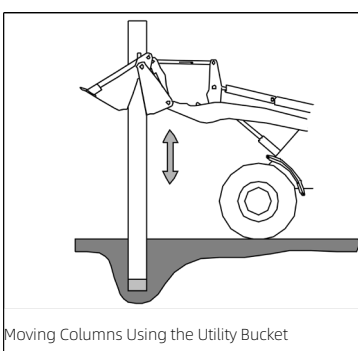

☞ Pulling out bulky material:

- Open the multipurpose bucket and lower it over the post. Close the bucket to grip the post firmly
- Loosen the post with careful up-and-down movements

Backfilling round gravel and precise unloading

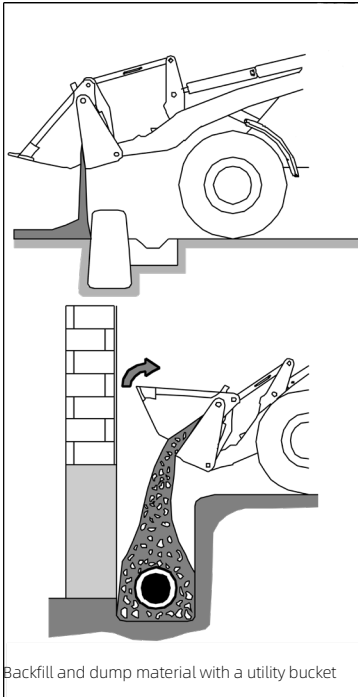

☞ Backfilling round gravel:

- Precise dosing and placement of pourable material
- When opening the bucket, do not let bucket teeth touch the wall

Unloading from the bottom of the bucket for increasing dump heights

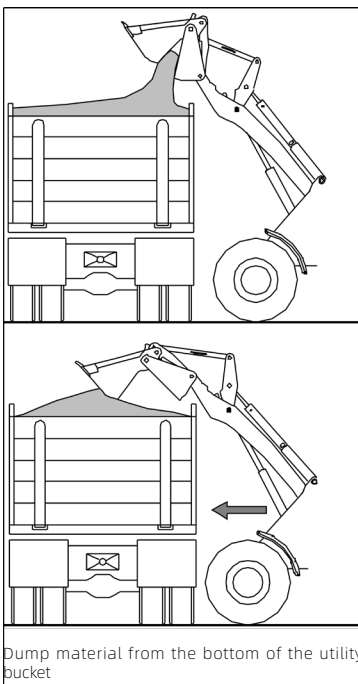

☞ Unloading from the bottom of the bucket for increasing dump heights:

- Compared with the standard bucket, the dump height increases dramatically (depending on bucket size)



Important !

According to the picture, smaller dump reach is compensated by pushing the material with the open multipurpose bucket.

3.33 Fitting pallet forks

Picking up pallet forks with the quick hitch



Important !

- The pallet forks are picked up and mounted on the quick hitch in the same as the standard bucket.
 - ☞ You must be able to see the lock pins from the holes on the attachment
-



Danger !

- Before starting work, make sure the attachment is safely locked on the quick-hitch by means of the lock ram.
- ☞ You must be able to see the lock pins on either side in the mounting bores on the attachment!
-

Removing the pallet forks from the quick hitch



Important !

- The pallet forks are removed from the quick hitch in the same way as the standard bucket.
 - You must be able to see the lock pins on either side in the mounting bores on the attachment!
-



Danger !

- Before starting work, make sure the attachment is locked safely on the quick hitch by lock pins.
- ☞ You must be able to see the lock pins on either side in the mounting bores on the attachment!
-

3.34 Working with the pallet forks

General safety instructions regarding the pallet forks

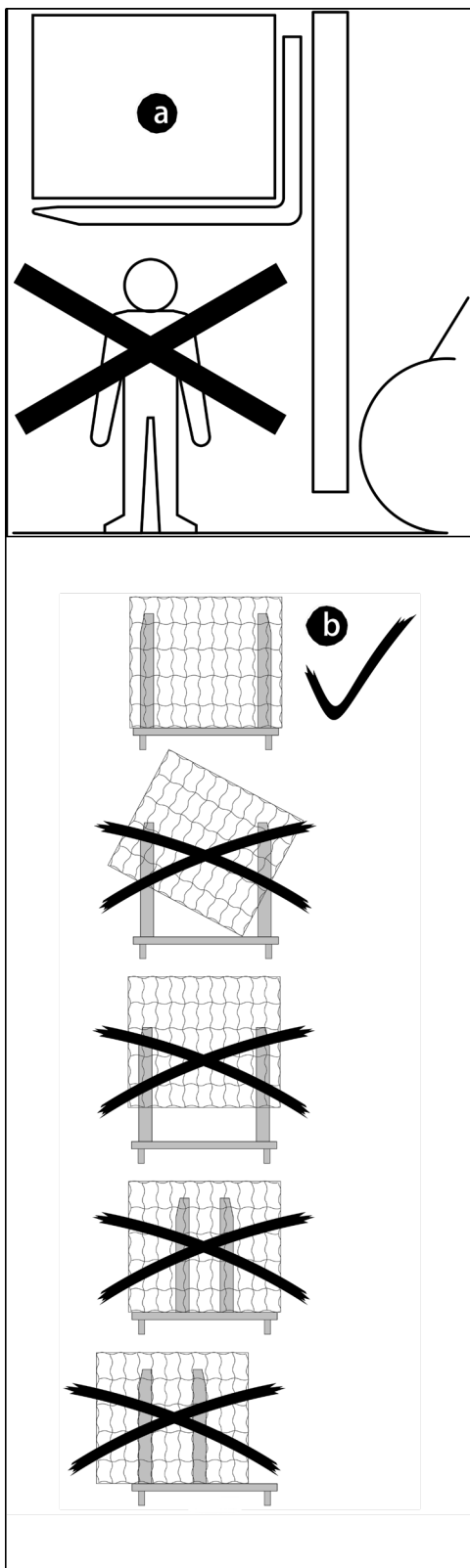

- In order to avoid accidents, please do not raise material when transporting!
- Approach the material as closely as possible!
- Always approach the material with the machine wheels in straight-ahead position!
- Always load on firm and level ground with sufficient load-bearing capacity only (for fully loaded machine)!
- Never raise a load with only one fork arm!
- Maintain a distance of a minimum 6m between the loader unit/load and overhead lines!
- Before starting work, make sure the fork arms on the fork frame are safely locked!
- Never operate the loader unit and the attachments at higher machine speed!
- Never leave the machine with the load raised!
- Always transport the load close to the ground!
- Make sure only authorized persons handle and work with the attachment
- Do not transport persons in the attachments
- Stay clear of suspended loads (figure a)
- Never use the controls or movable lines and cables as handles
- Never use bent, cracked or otherwise damaged fork arms/ pallet forks!
- Do not drive on public roads with an attachment fitted on the machine!
- Move the fork arms all the way through under the pallets, as far as they will go, so that the load is picked up the nearest possible to the fork frame.
- Move under the load with the straight fork arms as far apart as possible and at an equals distance from the left and right side of the load b!
- Lock the adjustable fork arms with the locking lever before moving the machine with loaded or unloaded pallet forks, to prevent the fork arms from moving (slipping, sliding) sideways!
- Loads must only be set down on a suitable vase with sufficient stability and load-bearing capacity!
- Do not stack or set down in higher places loads which are not properly packaged or which have shifted, or load units with damaged pallets or stacking containers.
- Always tilt in the attachment a little for transport (towards the machine) !
- Lower the bucket the nearest possible to the ground for transport. O serve minimum ground clearance!
- Drive slowly with a raised load, especially in off-road applications, to avoid strong swinging movements of the load!
- When driving or working across a slope, the load must be on the uphill side of the machine/attachment. Drive the machine backwards on sloping terrain to prevent the lad from falling off and the machine from tilting forwards when braking.

- When transporting large bulk loads drive the machine backwards for improved visibility
- Observe the load-bearing capacity of bridges, basement ceilings, vaults etc. before moving the machine on them!
- Bear in mind the clearances of underpasses, tunnels, gates etc. before driving through or under them!
- Do not overload the attachment or the machine, observe the load diagram!
- Set down loads only in places where they will stand safely without tilting, falling down or sliding
- Observe the load-bearing capacity of the set-down area (e.g. truck platforms, storage area in high-bay warehouse etc.)
- Load the loading area of vehicles or trailers evenly and distribute the load evenly on the axles
- Stack loads only up to the authorized maximum pallet height
- Do not set down loads too near to slopes, constructions pits etc.
- Set down loads only in the areas provided for within the construction site. Affix appropriate marks to loads which have been set down, especially in the area of public and private traffic.
- Do not set down loads in transit or escape routes, and not in front of safety facilities or works equipment which must be accessible at any time.

Adjusting the fork arms of the pallet forks

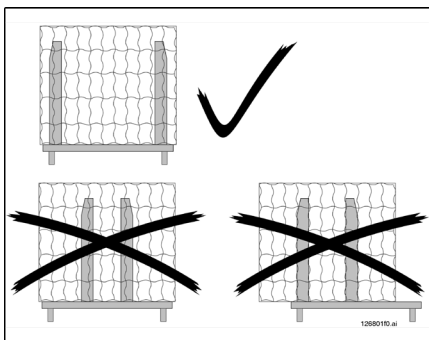

Danger !

In order to prevent fork arms from slipping or sliding sideways, the safety pins of the fork arms must be correctly locked in the notches on the fork frame.

☞ Before using the pallet forks, check whether both locking levers on the fork arms are folded down and safely engaged in the fork frame !

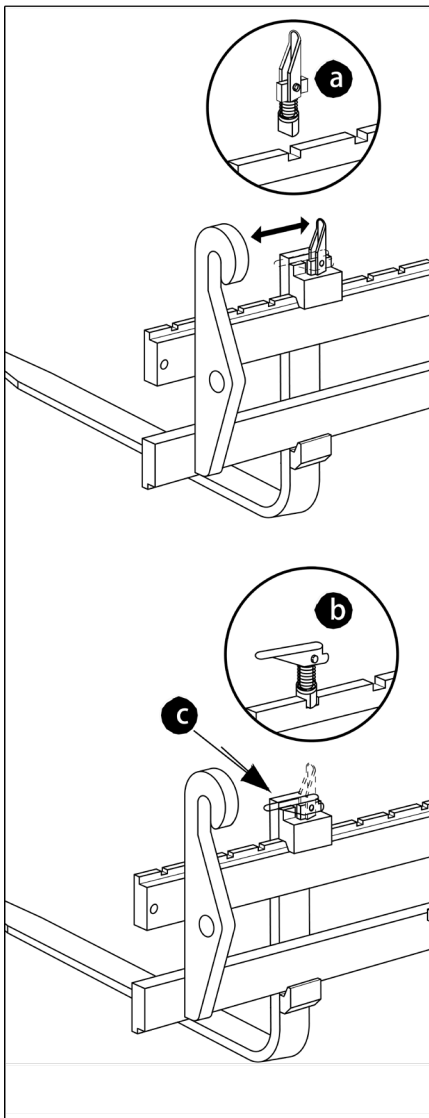

- When the fork arms must always be evenly aligned with the fork frame.

- The fork arms must always be evenly aligned with the fork frame

- ☞ Adjust the fork arms as follows :

- Set the locking lever to the vertical position a

- The fork arms can be moved on the fork frame

- Slide the fork arms to the required distance until the safety pin engages in a slot on the fork frame

- Fold down the locking lever again, position b

- The upper edge of the locking lever must be flush with the edge C

Fields of application for pallet forks

- Pallet forks are mainly used for picking up, transporting and loading pallet used material and staple commodities.

- Get informed on the legal regulations of your country which may prohibit driving on public roads with loaded pallet forks.

- The machine and attachment may be used for applications with lifting gear only if the prescribed safety devices are in place and functional.

Picking up loads with the pallet forks

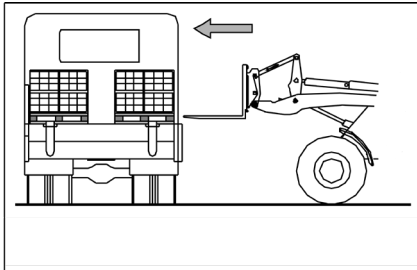

☞ Pick up loads as follows
 Move the wheel loader up to the load so that the pallet forks or the fork arms are at a right angle to the load
 The fork arms must be the furthest possible apart, and at an equal distance from the left and right side of the load

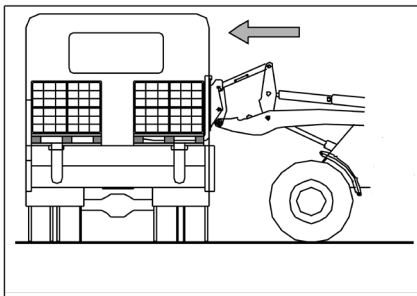

- Drive the wheel loader forwards and move the fork arms as far as possible under-neath the pallet
- The load must fit close to the fork frame

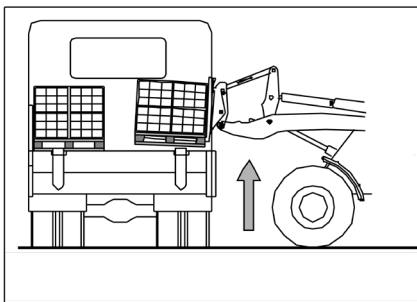

- Carefully raise the load:
- Slightly dump in the load



Caution !

Do not exceed the loader's output limit.

Transporting loads with the pallet forks



Danger!

When transporting loads with the pallet forks raised, the load can fall down or the machine can tilt!

- ☞ Dump in the pallet forks a little and lower them to transport position
- ☞ If necessary, raise the pallet forks just before setting down the load
- ☞ Never raise the load over persons
- ☞ Never park the machine with a raised load
- ☞ Avoid any operation that might be a risk to machine stability

Operation

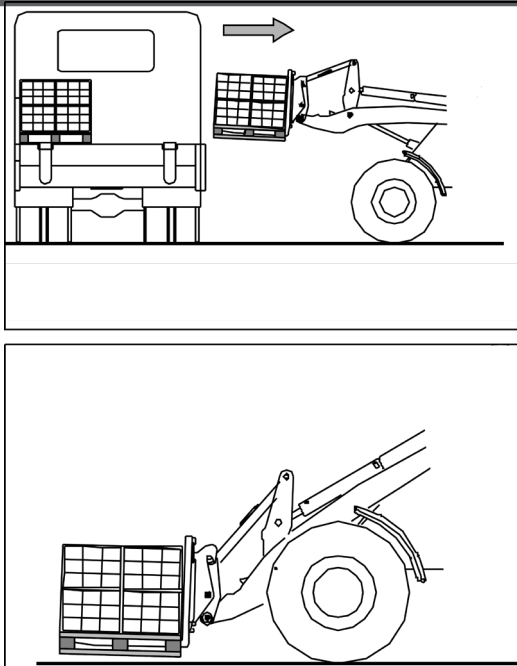

☞ Transport loads as follows:

- Move the load only when it is safely placed on the fork arms.
- Drive the machine only if you have sufficient visibility.
- Start, turn and stop smoothly.
- Concentrate on your work, avoid distractions
- Lower/raise loads to transport position before moving and transporting them (bear in mind the ground clearance)
- Always tilt in the pallet forks a little towards the machine for transport.
- Always drive slowly, especially in off-road applications, to avoid strong swinging movement of the load!
- When driving or working across a slope, the load must be on the uphill side of the machine/ attachment. Drive the machine backwards on sloping terrain to prevent the load from falling off and the machine from tilting forwards when braking!
- When transporting large bulk loads drive the machine backwards for improved stability.

3.35 Trailer coupling

General information on the trailer coupling

The trailer coupling can finish most trailing work, but please be careful when working with it.



Danger!

Add extra weight to the loader during trailer operation!
☞ Raise the bucket and lock it in the quick hitch.

Trailer loads on the trailer coupling



Caution !

Before coupling a trailer, bear in mind if the trailer weights meet the weight of the machine and trailer coupling.

Trailer coupling operation



Danger!

In order to avoid danger of accidents, always check that the trailer is correctly and safely coupled on the trailer coupling.

☞ Keep your hands clear of the coupling when checking (danger of crushing!)

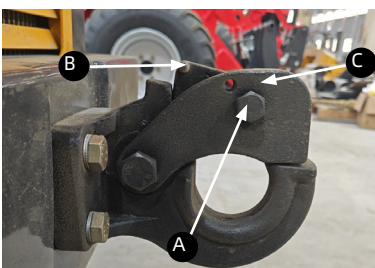

- Pull out the safety lock pin A
- Pull up the handle B, and at the same time lift hook C
- Install the lifting belts or similar equipments as required.
- Implement trailing operation

3.36 Final decommissioning of machine

General information on decommissioning

If the wheel loader no longer used according to its designated use, make sure it is decommissioned or taken out of service and disposed of according to applicable regulations.

Preparing disposal

Follow all applicable safety regulations regarding machine decommissioning !

- Make sure the machine cannot be operated between decommissioning and disposal !
- Make sure there is no leakage of environmentally hazardous consumables, and that the machine presents no other hazards at its storage place !
- Make sure the loader unit is fully lowered and that the bucket is placed horizontally on the ground ! Mount all protective devices!
- Make sure the parking brake is used to park the machine safely and prevent it rolling away and that the machine is secured in addition by placing chocks under the downhill sides of the wheels !
- Secure the machine against unauthorized use ! Safely lock all openings (doors, windows, engine cover) of the machine!
- Repair all leaks on the engine, tanks, gearbox and hydraulic system!
- Remove the battery!
- Store the machine at a location that is secured against access by unauthorized persons



Environment!

Avoid environmental damage!

Do not allow the oil and oil wastes to get into the ground or stretches of water!

Dispose of different material and consumables separately and in an environmentally friendly manner!

Disposal

Further recycling of the machine must be made in accordance with state-of-the-art standards applicable at the time of recycling, and in compliance with the safety regulations regarding accident prevention !

- All parts must be disposed of (depending on material) at appropriate sites !
- Separate the material as you recycle parts !
- Ensure environmentally compatible disposal of consumable as well !

4 Troubleshooting

The information give in this chapter is provided for maintenance staff, for fast and reliable detection of malfunctions and their appropriate repair.

Repairs must be carried out by authorized staff.

4.1 Engine trouble

Engine trouble	Possible causes	Remark
	Engine starting temperature too low	
	Engine lubricating oil not comply with specifications	
	Fuel does not comply with specifications	
	Battery is defective or dead	
	Loose or oxidized cable connections in starter circuit	
	Defective starter, or pinion does not engage	
	Defective fuel injector	
Engine starts, but does not run smoothly	Fuel does not comply with specifications	
	Injection line leaks	
	Defective fuel injector	
Engine overheats, temperature warning system responds	Oil level too low	
	Oil level too high	
	Dirty air filter	
	Dirty oil radiator fins	
	Defective fan, torn, or loose V-belt	
	Resistance in cooling system too high, flow capacity too low	
	Defective fuel injector	

Engine trouble		Possible causes	Remarks
Insufficient engine output		Oil level too high	
		Fuel grade does not comply with specifications	
		Insufficient engine output	
		Fuel grade does not comply with specifications	
		Dirty air filter	
Engine does not run on all cylinders		Injection line leaks	
		Defective fuel injector	
Insufficient or no engine oil pressure		Oil level too low	
		Engine does not run on all cylinders	
		Defective fuel injector	
Engine oil consumption too high		Oil level too high	
		Insufficient or no engine oil pressure	
	Blue	Oil level too high	
		Engine inclination too high	
	White	Engine starting temperature too low	
		Engine oil consumption too high	
		Engine inclination too high	
	Black	Dirty air filter	
		Defective fuel injector	

5 Maintenance

5.1 Important information on maintenance and service work

Important information for maintenance personnel

Working conditions and the service life of the wheel loader are heavily dependent on maintenance.

Daily and weekly service and maintenance work must be carried out by a specifically trained driver.

All other maintenance work must be carried out only by the trained and qualified staff of your sales partner or workshop.



Important !

Support maintenance and service regularly, even though there is no problem for machines operation.

- Before carrying out service and maintenance work, always make sure:**
- that the machine is parked on level and firm ground and that it cannot roll away under its own weight.
 - that the engine is stopped and the ignition key removed.
 - Before starting welding or repair work on the electrical system, the cable on the negative terminal (-) of the battery is disconnected !
 - that the maintenance and safety instructions in the manual should be complied with



Danger!

Do not carry out assembly and maintenance work if the loader unit is raised and not secured-danger of crushing and injury!

- ☞ Secure the loader unit with an appropriate prop or support to prevent it from being lowered unintentionally
 - ☞ Stop the engine and remove the ignition key
 - ☞ Apply the parking brake
-

5.2 Fuel system

Safety instructions for refueling

- Extreme caution is essential when handling fuel-high risk of fire !
- Never carry out work on the fuel system in the vicinity of naked flames or sparks !
- Do not smoke when working on the fuel system or when refueling !
- Before refueling, stop the engine and remove the ignition key !
- Do not refuel in closed rooms!



Environment !

Use a suitable container to collect the fuel and dispose it in an environmentally friendly manner! Keep the machine clean to reduce the risk of fire and wipe away fuel spills immediately !

Diesel fuel specification



Caution! !

Only use the qualified diesel fuel !

☞ If using other fuels, such as gasoline, warranty rights will be lost!

Stationary fuel pumps

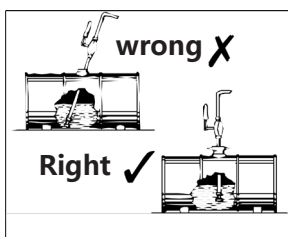

General instructions

Only refuel from stationary fuel pumps. Fuel from barrels or cans is usually contaminated. Even the smallest particles of dirt can cause increased engine wear.

- Malfunctions in the fuel system and
- Reduced effectiveness of the fuel **filters**

Refueling from barrels

If refueling from barrels cannot be avoided, note the following points:

- Barrels must neither be rolled nor tilted before refueling
- Protect the suction pipe opening of the barrel pump with a fine-mesh strainer
- Immerse it down to a max. 15 cm above the floor of the barrel
- Only fill the tank using refueling aids (funnels or filter pipes) with integral micro filter
- Keep all refueling containers clean at all times

Refueling

Danger !

In order to avoid intoxication and ride hazards, do not refuel in enclosed area !

☞ Never carry out work on the fuel system in the vicinity of naked flames or sparks



The fuel tank filler port is located on the left side of the front frame.



Important !

Capacity= about 30L



Caution! !

If the fuel tank is full to the brim, do not park the machine on extreme slopes ! The fuel can flow out of the tank if the cap is opened!

Check/clean the fuel filter



The fuel filter is fastened on the engine:

☞ Proceed as follows:

- Stop the engine
 - Apply the parking brake
 - Switch off ignition and remove the ignition key
 - Place a container to collect the fuel
 - Check and clean the fuel filter
 - Start the diesel engine and check the additional fuel filter for leaks
-



Environment!

Use a sustainable container to collect and discharge the fuel, and dispose it in an environmentally friendly manner !

Have further repair work carried out by an authorized workshop.

5.3 Engine lubrication system

Safety instructions regarding inspections and maintenance work on the engine

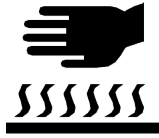

Danger!

Do not carry out maintenance work on a hot engine

- ☞ Wait at least 10 minutes after stopping the engine
- ☞ Wear protective gloves and clothing during maintenance work



Important !

Check the oil level every 10 service hours or once a day.
Check before starting the engine
After stopping the engine, wait at least 5 minutes before checking the oil level

Checking the engine oil level and oil filter



Caution!

If the engine oil level is too low or if an oil change is overdue, this can cause engine damage or loss of output!

- ☞ Have the oil drained every 500 service hours by an authorized workshop.

☞ Check the engine oil as follows:

- Park the machine on level ground
- Stop the engine
- Apply the parking brake and open the engine cover
- Pull out the oil dipstick and wipe it with a lint-free cloth
- Push it in as far as possible, pull it back out again and read off the oil level
- Fill up the oil when the oil reaches the MIN mark on oil dipstick A

☞ Check the oil filter as follows:

- Park the machine on the level ground
- Stop the engine
- Apply the parking brake and open the engine cover
- Check the oil filter
- Decide if changing the oil filter as required
- Test whether the engine works normally

Filling up engine oil



Caution!

Too much or incorrect engine oil result in engine damage!
☞ Do not add engine oil above the MAX mark of the oil dipstick A



Environment !

Use a suitable container to collect the engine oil as it drains and dispose of it in an environmentally friendly manner

☞ Fill up the engine oil as follows:

- Clean the area around oil filler cap with a lint-free cloth
- Open filler cap
- Fill up the engine oil
- Wait a moment until all the oil has run into the oil sump
- Check the oil level with oil dipstick
- Fill up oil if necessary and check the oil level again
- Close filler cap and completely remove all oil spills from the engine

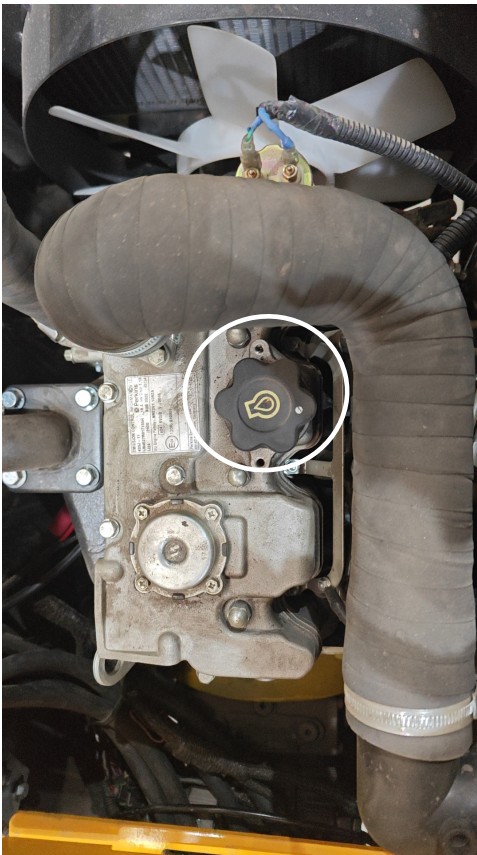

5.4 Engine and hydraulics cooling system

General instructions regarding cooling system maintenance

The combined oil/water radiator cools the diesel engine and the hydraulic oil of the drive and work hydraulics.

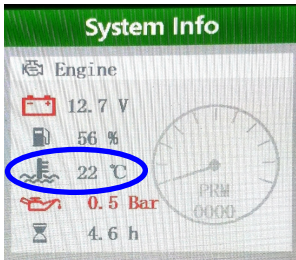

Caution!

Engine temperature should be between 80 and 105 degrees Celsius

Max. Admissible engine temperature is 110 degrees Celsius

☞ An alarm sounds if the engine temperature is 115 degrees Celsius or higher.

☞ To cool down: let the engine run at idling speed briefly then switch it off.

•The alarm no longer sounds if the engine temperature is 110 degrees Celsius or lower

☞ Check the cooling system



Danger!

Danger of swallowing antifreeze when handling it !

☞ Seek medical attention immediately if antifreeze has been swallowed

☞ Wear protective clothing and gloves

☞ Keep antifreeze out of reach of children

General checks and cleaning work

Dirt on the radiator fins reduces the radiator's heat dissipation capacity !

•Check the radiator once a day for dirt and clean it if necessary.

•In dusty or dirty work conditions, clean more frequently than indicated in the maintenance plan

•An insufficient coolant level reduces the heat dissipation capacity and can lead to engine damage !

•Check the coolant level regularly!

•If the coolant must be replaced frequently, have the cooling system checked for leaks by an authorized workshop !

•Never fill in cold water/coolant if the engine is warm !

•After filling the coolant, make a test run with the engine and check the coolant level again after stopping the engine.

•Add enough antifreeze to the coolant

•Use brand name antifreeze compounds with anti corrosion additives.

•Do not use radiator cleaning compounds if an antifreeze compound has been added to the coolant, otherwise this causes sludge to form that can damage the engine.



Environment!

Use a suitable container to collect the coolant as it drains and dispose of it in an environmentally friendly manner!

Cleaning the radiator fins of the oil/water radiator

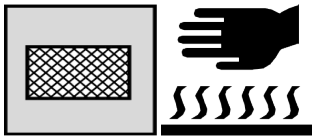

Danger!

Danger of burns ! Do not carry out maintenance work on a hot engine and hydraulic system!

- ☞ Wait at least 10 minutes after stop the engine
 - ☞ Wear protective clothes and gloves during maintenance work
-



Caution!

Dirt on the radiator fins reduces the radiator's heat dissipation capacity and can cause damage to the engine and the hydraulic system !

- ☞ Check the radiator once a day for dirt and clean it if necessary
 - ☞ Clean the radiator more frequently in dusty or dirty work conditions
 - ☞ Do not damage the radiator fins as you clean them with a compressed-air gun
-



☞ Clean as follows:

- Park the wheel loader on level ground
- Lower the loader unit fully
- Apply the parking brake
- Stop the engine and let it cool down
- Switch off ignition and remove the ignition key
- Clean radiator fins with water gun

Checking the coolant level

The coolant expansion tank is located above the radiator, open the cover and check if the coolant is enough

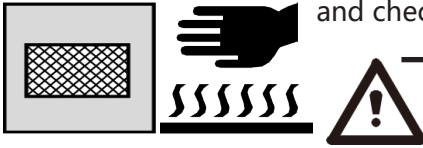

Danger!

Danger of burns! Never open the coolant tank and never drain coolant if the warm engine is running since the cooling system is under high pressure.

- ☞ Wait at least 10 minutes after stopping the engine!
- ☞ Wear protective gloves and clothing
- ☞ Open the cap carefully.



Important !

Check the coolant level every 10 service hours or once a day.

- ☞ Check the coolant level as follows:
 - Park the machine on level ground
 - Lower the loader fully
 - Apply the parking brake
 - Stop the engine and wait
 - Switch off the ignition and remove the ignition key, and wait the engine cool.
 - Open the radiator cover and open the cap of coolant expansion
 - Check the coolant level by eyes

If the coolant level is too low:

- Fill up coolant
- ☞ Check the coolant quality (antifreeze) with suitable testing equipment (antifreeze tester)

Filling up coolant



☞ Fill up coolant as follows

- Park the machine on level ground
- Lower the loader unit
- Apply the parking brake
- Switch off ignition and remove the ignition key
- Allow the engine/cooling system to cool down
- Open filler cap
- Fill up the coolant
 - ➔ Use brand-name antifreeze compounds with anticorrosion additives.
- Close and tighten the filler cap

☞ Check the coolant level

- Open the heating circuit
- Start and warm up the engine
- Stop the engine
- Check the coolant level again
 - ➔ If necessary, fill in coolant and repeat the procedure until reaching the correct coolant level!
- Check the cooling system and the heating water circuit for leaks
- Have leaks immediately repaired by an authorized workshop

5.5 Air filter

Checking the air filter for dirt

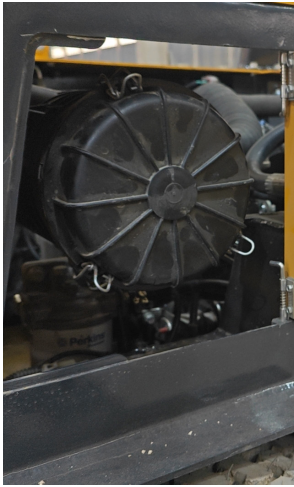

Caution!

Bear in mind the following to avoid premature engine wear:

- ☞ Do not wash, brush or clean with compressed air
- ☞ Replace the filter when the telltale comes on
- ☞ Never reuse a damaged filter
- ☞ Ensure cleanliness when replacing the filter
- ☞ Do not clean the safety filter, replace it on time

☞ Replace the air filter cartridge as soon as telltale A on the dash board comes on

- At the latest after 1500 service hours (however once a year)

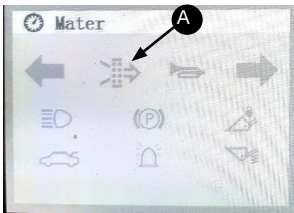

Caution!

Filter cartridges degrade prematurely when in service in acidic air for longer periods of time!

Replacing the air filter cartridge

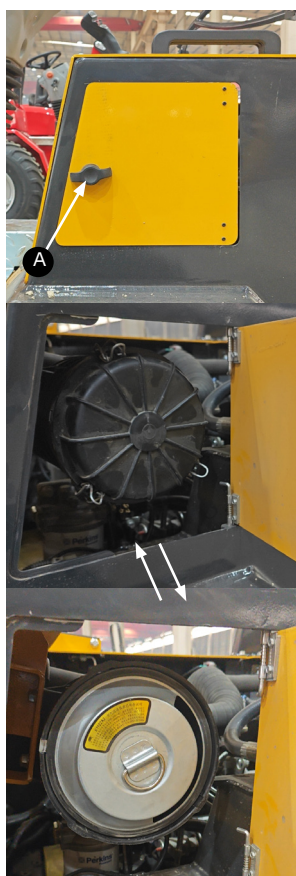

☞ Replacing as follows:

- Stop the engine
- Set wheel chocks
- Rotate A to the right and open the air filter access door
- Open all buckles and remove the cap
- Remove the filter cartridges



Caution!

Before inserting the new filter, make sure all dirt inside the upper and lower housing sections has been removed !

- Carefully insert new safety cartridge
- Close the cap and lock all buckles

5.6 V-belt

Checking V-belt tension

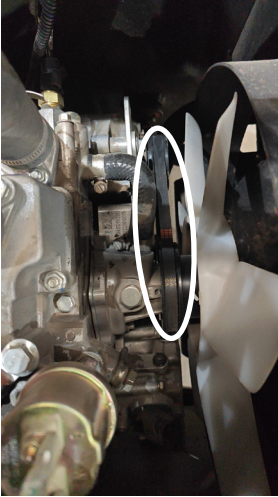

Danger !

Caution, turning parts! Only check or replace/retighten the V-belt when the engine is stopped!

☞ Stop the engine before carrying out inspection work in the engine compartment!



Caution !

Cracked and stretched V-belts cause engine damage

☞ Replace the V-belt every 2 years at the latest

☞ Have the V-belt replaced by an authorized workshop

Check the V-belt once a day or every 10 service hours, and retighten if necessary! Retighten new V-belts after about 15 minutes of running time.

☞ Check as follows:

- Stop the engine
- Prevent the machine from rolling away and remove the ignition key
- Carefully inspect V-belt for damage
- If the V-belt is damaged:

☞ Have the V-belt replaced by authorized staff

- Retighten the V-belt if necessary

Retightening the V-belt

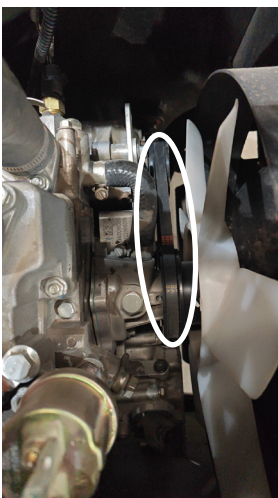

☞ Retightening as follows:

- Stop the engine
- Put wheel chocks and remove ignition key
- Slacken fastening screws of alternator
- Use a suitable tool to push the alternator until the correct V-belt tension is obtained
- Keep the alternator in this position, and at the same time retighten fastening screws
- Start the engine
- Check the V-belt tension after 15 minutes

5.7 Hydraulic system

Safety instructions regarding maintenance of the hydraulic system

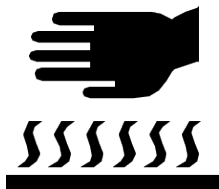

Danger!

Danger of burns! Do not carry out maintenance work on a hot engine and hydraulic system

- ☞ Wait at least 10 minutes after stopping the engine
- ☞ Wear protective gloves and clothing during maintenance work



Caution!

Hydraulic oil escaping under high pressure can penetrate the skin and cause serious injuries

- ☞ Even if the wound seems insignificant, always consult a doctor immediately
- otherwise serious infections could set in!

- Release the pressure in all lines carrying hydraulic oil prior to any maintenance and repair work. To do this:
 - Lower all hydraulically controlled attachments to the ground
 - Stop the engine and apply the parking brake
 - Move all control levers of the hydraulic control valves several times
 - Only use authorized oils of the same type
 - Always fill in hydraulic oil before the level gets too low
 - If the hydraulic system is filled with biodegradable oil, then only use biodegradable oil of the same type for filling up, otherwise will cause damages.
 - Collect drained hydraulic oil in a suitable container
 - Dispose of drained oil and used filters by an ecologically safe method.



Caution!

If the hydraulic oil in the tank is cloudy, this indicates that water or air has penetrated the hydraulic system.

Contaminated hydraulic oil, lack of oil or wrong hydraulic oil - danger severe damage to the hydraulic system!

- ☞ Have the oil immediately replaced

Monitoring the hydraulic oil and the reflux filter

On the dash board, the red telltale A monitors the reflux pressure, the telltale B monitors the oil temperature.

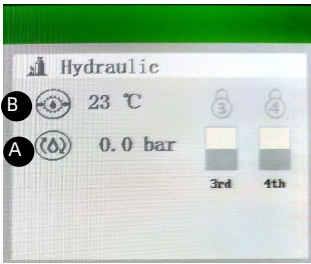

Caution !

If the flow resistance in the reflux filter is too high, telltale A comes on! Proceed as follows:

The filter element is dirty and must be replaced.

Drain the hydraulic oil in case of increased contamination, however after 1500s/h at the latest or once a year

The filter element and the hydraulic oil may be replaced by an authorized workshop only!

If the hydraulic oil is too high, telltale B comes on! Proceed as follows:

Check the hydraulic oil level (not enough oil in the tank)

Replace the filter element (highly contaminated filter)



Important !

Telltale B on the dashboard comes on in the cold weather immediately after starting the engine. This is caused by increased oil viscosity. In this case::

- Set engine speed so that the telltale goes out
- Bear in mind the instructions concerning warmup

Checking the hydraulic oil level

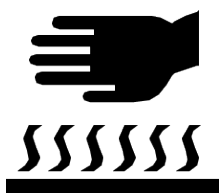

Danger!

Danger of burns! Do not carry out maintenance work on a hot engine and hydraulic system!

- ☞ Wait at least 10 minutes after stopping the engine!
- ☞ Wear protective gloves and clothing during maintenance work!



☞ Proceed as follows:

- Park the machine on level ground
 - Retract all hydraulic rams
 - Stop the engine
 - Apply the parking brake
 - Open the engine cover
 - Open the air filter in the hydraulic oil tank, check the level:
- ☞ **If the oil level rod has the oil strain**
- ➔ OK
- ☞ **If the oil level rod does not have the oil strains**
- ➔ Fill up hydraulic oil



Caution!

As soon as the temperature rises, any excess quantity of hydraulic oil in the tank escapes via the breather

Filling up hydraulic oil

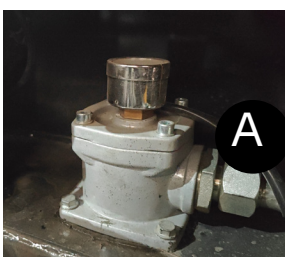

Do not fill up the hydraulic oil unless the engine is stopped. Otherwise, hydraulic oil will run out of the filter opening on the hydraulic tank.

☞ Fill up as follows:

- Park the machine on level ground
 - Retract all hydraulic rams
 - Stop the engine
 - Apply the parking brake
 - Open the engine cover
- ☞ **Filing up:**
- If using specialized equipment to fill up the hydraulic oil, open the screw of 4 reflux oil filters to fill up
 - Tighten the cap after filling up
 - Without specialized equipment, open the cap of the air filter B to fill up
 - After filling up, tighten the air filter



Caution!

No matter what ways of filling up are used, make sure the working environment and operating equipment are clean.

5.8 Checking hydraulic pressure lines

Safety instructions regarding pressure line checks



Danger!

Be careful when checking hydraulic pressure lines, especially when searching for leaks.

Hydraulic oil escaping under high pressure can penetrate the skin and cause serious injuries.

☞ Always consult a doctor immediately, even if the wound seems insignificant-otherwise serious infections could set in!

☞ Always comply with the following instructions:

- Retighten leaking screwed fittings and hose connections only when the system is not under pressure, release the pressure before working on pressurized lines!
 - Never weld or solder damaged or leaking pressure lines and screw connections. Replace damaged parts with new ones.
 - Never search for leaks with your bare hands, but wear protective gloves!
 - Have damaged flexible lines replaced by authorized workshops only!
-

The owner of the machine must ensure that flexible lines are replaced in appropriate intervals, even if no safety-relevant defects can be detected on the flexible line.

Flexible lines must be inspected by an expert (competent person) before the first commissioning, and then at least once a year for safe working condition.

• Leakages and damaged pressure lines must be immediately repaired or replaced by an authorized workshop or after-sales staff.

• Replace hydraulic hoses every 6 years from the date of manufacture, even if they are not broken.

In this respect, we recommend that you observe all the relevant safety regulations for hydraulic lines, as well as the safety regulations regarding accident prevention and occupational health and safety in your country.

5.9 Lubrication work

Safety instructions regarding lubrication work

- Park the wheel loader on level ground and prevent it from rolling away by applying the parking brake and placing wheel chocks
- Raise the loader unit and secure it with the safety strut on the lift arm
- Stop the engine and remove the ignition key



Caution!

Lubricate all lubrication points mentioned below with lithium-saponified brand-name grease.

Lubricating the rear axle oscillation-type bearing

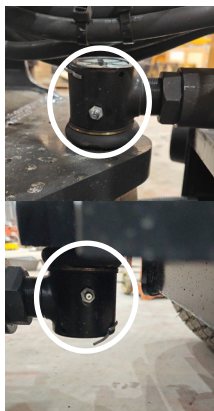

Important !

Lubricate once for each shift work (8-hour working), e.g. do this after working everyday.

☞ Two circled places in the left picture are lubricate grease nipples

Lubricating and steering system



Lubricate once for each shift (8-hour work), e.g. lubricate after working everyday.

☞ Two circled places in the left picture are lubricate grease nipples.

Lubricating the loader unit

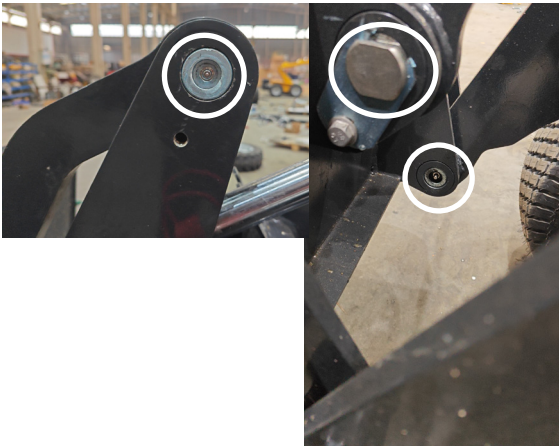

Lubricate once every shift (8-hour work), e.g. after finishing working and do this everyday

☞ the left picture are lubricate grease nipples



Lubricate once every shift (8-hour work), e.g. after finishing working and do this everyday.

☞ Six circled places in the left picture are lubricate grease nipples.

5.10 Maintenance of the brake system

Specific safety instructions regarding the brake system

Brakes are crucial to safety. Incorrect maintenance can cause brake failure. Therefore all repair work on the brakes must be carried out by trained staff. An exception to this is the following work which must be carried out by the driver/operator:

- Daily check of the brake pad.
- Daily check of the brake disc.



Danger!

Defective brake pads or discs carry a danger of accident !
☞ Damaged brake pads or discs must immediately be replaced. !

5.11 Tyres

Daily tyre checks



Danger!

All repair work on tyres and rims may only be carried out by authorized persons or workshops.



Important !

Regular inspections of the tyres

- Improve operating safety
- Increase the service life of the tyres
- Reduce machine downtimes

The authorized tyre types and the correct tyre pressures

- Check Tyre pressure
- Check tyres and rims for damage (cracks, aging etc.)-also on the inside
- Remove foreign bodies from the Tyre tread
- Remove traces of oil and grease from the tyres

Wheel change



Danger!

Use only the wheels that have been suitable for the machine.

☞ Use suitable assembly tools, such as covering sleeves for the studs, a jack etc.

☞ Check the wheel nuts for tightness after every wheel or tyre change

☞ **Remove the wheels as follows:**

- Park the machine on level and firm ground and prevent it from rolling away
- Loosen the wheel nuts a little of the wheel you want to remove
- Place a jack under the axle, making sure it is standing firmly
- Raise the side of the axle from which you want to remove the wheel
- Check the machine is standing firmly
- Completely remove the wheel nuts
- Remove the wheels

☞ **Mount the wheels as follow:**

- Place the wheel onto the wheel studs
- Tighten all wheel nuts part-way
- Lower the raised axle
- Tighten the wheel nuts to the prescribed tightening torque

5.12 Electrical system

General instructions

Maintenance and repair work on the electrical system (including the battery) may be performed only by trained staff and/or authorized workshops!

Safety instructions regarding the electrical system and the battery

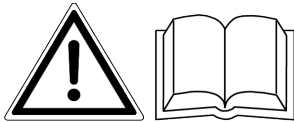

The battery contains sulphuric acid! This acid must not be allowed to come into contact with the skin, the eyes, clothing or the machine. Therefore when recharging or working near the battery, always wear goggles and protective clothing with long sleeves.

If acid is spilt:

- Thoroughly wash any part of the body touched by the acid immediately with plenty of water and seek medical attention at once.
- Immediately rinse acid splashes in the eyes with clear water for several minutes! Then seek medical attention at once.
- Immediately neutralize acid splashes on skin or clothing with an acid neutralizer or soap, and rinse with plenty of water
- Immediately seek medical attention if acid has been swallowed.
- Thoroughly rinse all affected surfaces immediately with plenty of water

Battery maintenance—danger of explosion

- Avoid naked flames and sparks and do not smoke in the vicinity of open battery cells, otherwise gas can ignite.
- When charging batteries, as well as during normal operation of batteries, an oxyhydrogen mixture is formed in the battery cells
- Do not try to start the machine quickly if the battery is frozen or if the acid level is low. The battery can explode.
- Disconnect the negative (-) battery terminal from the battery before starting repair work on the electrical system.

Jump-starting

- Use only 12 V power sources. Higher voltages will damage the electric components.
- When connecting the battery leads, make sure the poles +/- are not inverted, otherwise sensitive electric components will be damaged.
- Danger of sparking! Do not interrupt voltage-carrying circuits at the battery terminals.
- Never place tools or other conductive articles on the battery—danger of short circuit!

Putting the machine out of operation

- Remove the battery, store it in a dry and frost-free place
- If the machine is put out of operation for extended periods, charge the battery every 2 months or use a battery charge maintainer.
- Always charge it when storing it. The sulphate on of the electrodes causes lasting damage! A flat battery must be recharged as soon as possible.

Before putting the machine into operation

- Charge the battery and clean the terminals before installing it

Disposal of old battery

- For safe transport to a recycling point, place the protective cap on the positive terminal of the old battery and dispose of it properly.

Checking/replacing the battery

Checking/replacing the battery



Danger!

When changing batteries, as well as during normal operation of batteries, an oxyhydrogen mixture is formed in the battery cells with danger of explosions or corrosions.

☞ Therefore when recharging and/or working near the battery:

- Always wear goggles and protective clothing with long sleeves
- Open the caps of the battery openings by half a revolution before recharging the battery

☞ If acid is spilt:

- Wash all affected surfaces immediately with plenty of water!
 - Wash any part of the body touched by the acid immediately and seek medical attention at once!
 - Avoid naked lights and sparks in the vicinity of the battery and do not smoke.
 - Before starting repair work on the electrical system, always disconnect the negative terminal (-) from the battery!
-

The battery is located under the front frame cover.

☞ Replace the battery as follows:

- Apply the parking brake
- Switch off the ignition and remove the ignition key



Caution!

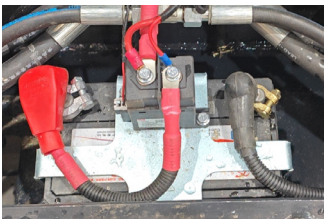

• In order to avoid short circuits when disconnecting the battery leads, always bear in mind the order for removing the leads under all conditions:

• Disconnecting the leads:

• First remove the negative terminal (-) lead, then the positive terminal (+) lead

• Mounting the leads:

• First fasten the positive terminal (+) lead, then the negative terminal (-) lead

• Remove battery fixture

• Replace the new battery

• Install the battery leads (bear in mind the order required for installing the cables)

• Install the fixed battery fixture

Inspection and maintenance work on the electrical system regularly

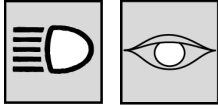

Daily checks before operating the machine

- Is the light system OK?
- Is the signaling and warning system OK?
- Is the ignition lock in working order?

Weekly checks

- Electric fuses: if defective, use only the specified load capacity (amperage)
→ Blown fuses indicate overloading or short circuits. Therefore, the electrical system should be checked by an authorized technician before installing the new fuse.

Check the alternator

- electric and earth connections: when carrying out maintenance work on the electrical system, pay particular attention to ensuring good contact in leads and fuses.
- Battery charge condition and condition of battery terminals

Checking the alternator

Always observe the following instructions:

- Only test run the engine with the battery connected
- When connecting the battery, make sure the poles (+/_) are not inverted
- Always disconnect the battery before carrying out welding work or connecting a quick battery charger
- Replace defective charge telltales immediately

Checking/replacing fuses and relays

The fuses and relays are located on many positions, please check the pictures.

☞ Checking/replacing fuses or switching relays

- Switch off ignition and disconnect the battery leads
- Replace defective fuses or relays as required



Fuse box, located under the battery

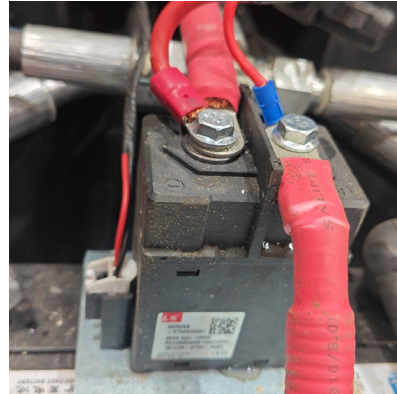

Power relay, located above the battery

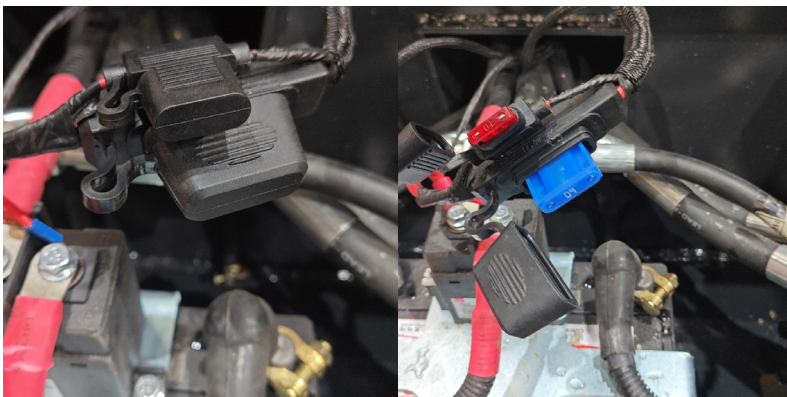

Mains fuse, located above the battery

5.13 General cleaning and maintenance work

Safety instructions regarding general cleaning work

Cleaning the machine is divided into 2 areas :

- Exterior of the machine
- Engine compartment

The wrong choice of cleaning equipment and agents can impair the operate safety of the machine, and undermine the health of the persons in charge of cleaning the machine. Please comply with the following instructions

Cleaning with washing solvents

- Ensure adequate room ventilation
- Wear suitable protective clothing
- Do not use flammable liquids, such as petroleum or diesel

Cleaning with compressed air

- Work carefully
- Wear goggles and protective clothing
- Do not aim the compressed air at the skin or at other people
- Do not use compressed air for cleaning your clothing

Cleaning with a high-pressure cleaner or steam jet

- Electric components and damping material must be covered and not directly exposed to the jet
- Cover the vent filter on the hydraulic oil tank and the filler caps for fuel, hydraulic oil.
- Cover the piston rods of the hydraulic rams(the scraper is not water proof, and water in the guide bushing causes corrosion and damage to the piston rod)
- Cover electric parts, such as the alternator, the ignition lock, the turn indicator, light switches, the relays etc.)
- Cover the controls and seals
- Cover the air-intake filter

Cleaning with volatile and flammable anticorrosion agents and sprays

- Ensure adequate room ventilation
- Do not use unprotected lights or naked flames
- Do not smoke

Cleaning the seat belt

- Clean the seat belt only with a mild soap solution; do not use chemical agents as they can destroy the fabric

Cleaning the exterior of the machine

The following articles are generally suitable:

- High-pressure cleaner
- Steam jet

Cleaning the engine compartment



Danger!

Caution, turning parts! Do not carry out maintenance work on a hot engine!

- ☞ Wait at least 10 minutes after stopping the engine
 - ☞ Wear protective gloves and clothing during maintenance work
-



Caution!

The engine must be cold before cleaning it with a water or steam jet

- ☞ Do not point the jet directly at the electric sensors such as the oil pressure switch!
 - The humidity penetrating any such sensors causes them to fail and leads to engine damage !
-

Checking screw connections



All screw connections must be checked regularly, even if they are not listed in the maintenance plans.

Tighten loose connections immediately.

Checking pivots and hinges



All mechanical pivot points on the machine (e.g. hinges, joints) and parts must be lubricated regularly, even if they are not listed in the lubrication plan.

Maintenance

Note:

