

contents

Flail Mower Assembly AGL.....	2
The Sway Frame Assembly.....	4
Blade Axle Subassembly.....	6

Flail Mower Assembly AGL

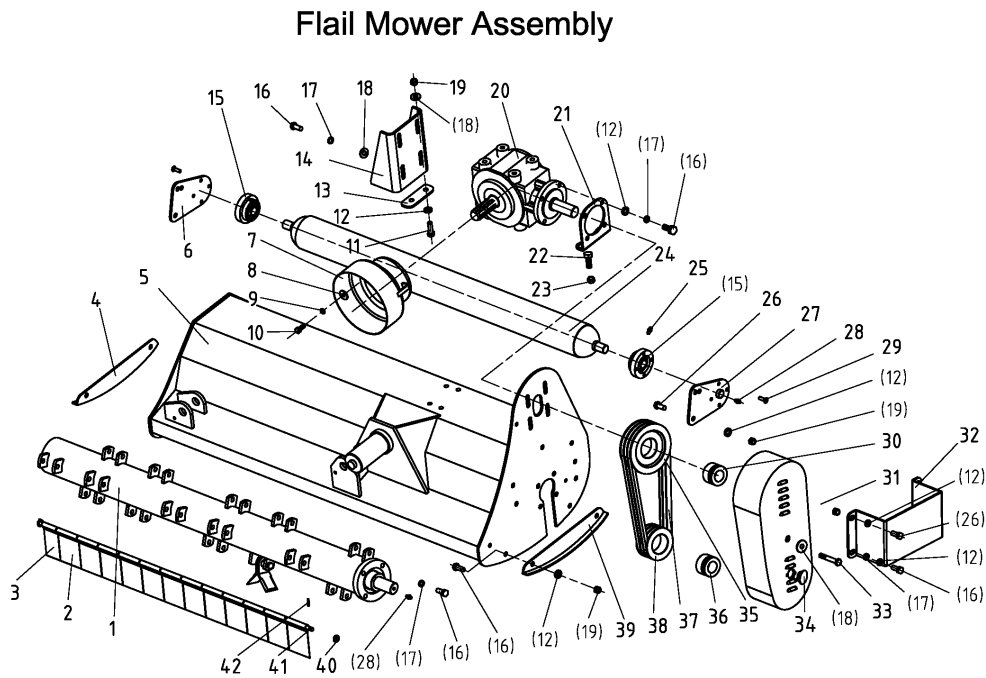

Flail Mower Assembly AGL			
No.	Part no.	Name and specification	Quantity
1-1	EFG100.013	blade axle	1
1-2	EFG120.013	blade axle	1
1-3	EFG140.013	blade axle	1
1-4	EFG160.013	blade axle	1
2	EF100.00.122	fender	12
3	EF100.00.121	fender	1
4	EFAGL125.022	base plate	1
5-1	EFAGL105.013	(105) hood	1
5-2	EFAGL125.013	(125) hood	1
5-3	EFAGL145.013	(145) hood	1
5-4	EFAGL165.013	(165) hood	1
6	EFAGL125.024	roller supporting	1
7	FM120.00.199	PTO cover	1
8	GB96.1-10	10 washer	4
9	GB93-10	10 washer	4
10	GB5783-M10X20	M10X20 bolt	4
11	GB5783-M12X40	M12X40 bolt	2
12	GB97.1-12	12 washer	10

13	EFGCHM120.101	plate	1
14	EFAGL125.015	gearbox rack	1
15	EF100.00.012	UC205 bearing	2
16	GB5783-M12X30	M12X30 bolt	20
17	GB93-12	12 washer	18
18	GB96.1-12	12 washer	7
19	DIN985-M12	M12 nut	8
20	XH50.300Z.02	(C884) gearbox	1
21	EFAGL125.014	lath	1
22	GB5783-M12X45	M12X45 bolt	2
23	GB6172.1-M12	M12 nut	2
24-1	EFG100.012	(105) roller	1
24-2	EFG120.012	(125) roller	1
24-3	EFG140.012	(145) roller	1
24-4	EFG160.012	(165) roller	1
25	GB1152-M6	M6 oil nipple	2
26	GB5783-M12X35	M12X35 bolt	4
27	EFAGL125.023	roller supporting	1
28	GB1152-M8X1	M8X1 oil nipple	4
29	GB70.3-M8X25	内 M8X25 bolt	8
30	REACH04-33X60	REACH 04 33X60 sleeve	1
31	EFGC130.016	皮带轮防护罩 belt cover	1
32	EFAGL125.110	belt cover protecting plate	1
33	GB5782-M12X110	M12X110 bolt	1
34	EF100.00.119	rubber cover	1
35	EFG120.106A	pulley	1
36	REACH04-35X60	REACH 04 35X60 sleeve	1
37	17X991	B991 belt	3
38	EFG120.105A	pulley	1
39	EFAGL125.012	base plate	1
40	GB97.1-10	10 washer	18
41-1	EF100.00.123	(105) flag shaft	1
41-2	EF120.00.123	(125) flag shaft	1
41-3	EF140.00.123	(145) flag shaft	1
41-4	EF160.00.123	(165) flag shaft	1
42	GB879.1-4X25	4X25 pin	2

The Sway Frame Assembly

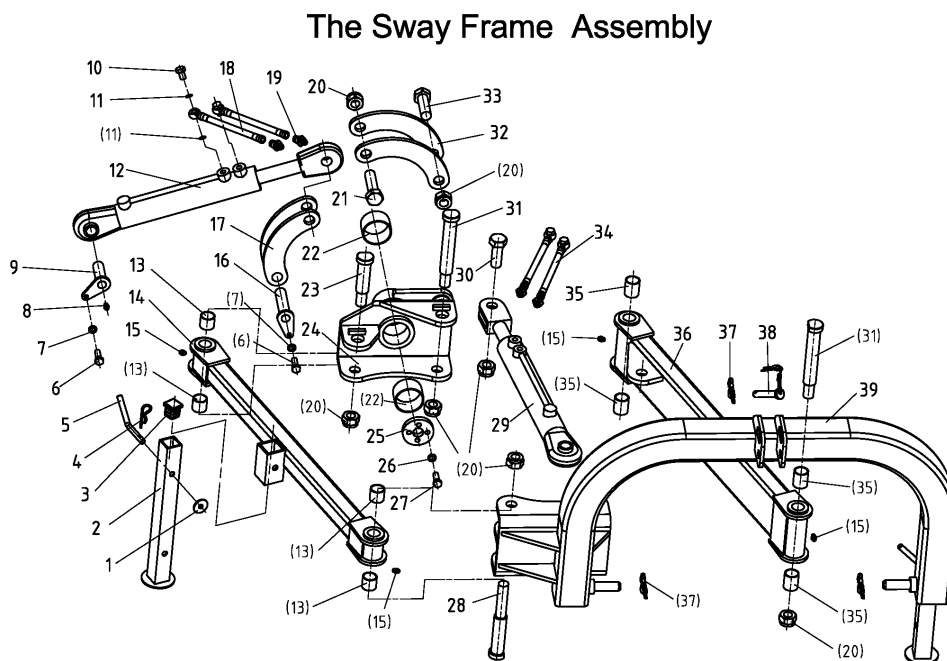

The Sway Frame Assembly

N0.	Part no.	Name & specification	Quantity
1	GB96.1-12	12 washer	2
2	EFAGL125.030	brace	2
3	MFP120.00.101	cover	2
4		R-pin	2
5	EF100.00.111A	D-pin	2
6	GB5783-M8X16	M8X16 bolt	2
7	GB93-8	8 washer	2
8	GB1152-M6	M6 nipple	1
9	EFAGL125.103-MH	locking pin	1
10	GB3541-M14X1.5	M14X1.5 bolt	4
11	JB982-14 (进)	14 washer	8
12	EFAGL125.016	cylinder	1
13	SF-2-30X34X30	bearing	4
14	EFAGL125.017	arm	1
15	GB1152-M10X1	nipple	5
16	EFAGL125.104-MH	pin	1
17	EFAGL125.021	plate	1
18	EFAGL125.025	oil pipe	2

19	QUICK-COUPLING-G1/2-G	R1/2" quick-coupling	4
20	DIN985-M24	M24 nut	7
21	GB5783-M24X90	M24X90 bolt	1
22	SF-2-65X70X40	65X70X40 bearing	2
23	EFAGL125.107	pin	1
24	EFAGL125.020	tube	1
25	EFAGL125.102	ring	1
26	GB97.1-10	10 washer	4
27	GB5783-M10X30	M10X30 bolt	4
28	EFAGL125.108	pin	1
29	EFAGL125.018	cylinder	1
30	GB5783-M24X65	M24X65 bolt	1
31	EFAGL125.109	pin	2
32	EFAGL125.105	plate	2
33	GB5783-M24X70	M24X70 bolt	1
34	EFAGL125.028	oil pipe	2
35	SF-2-30X34X40	30X34X40 bearing	4
36	EFAGL125.019	arm	1
37	200.56.011	locking pin	2
38	EF100.00.019	pin	1
39	EFAGL125.011	suspension	1

Blade Axle Subassembly

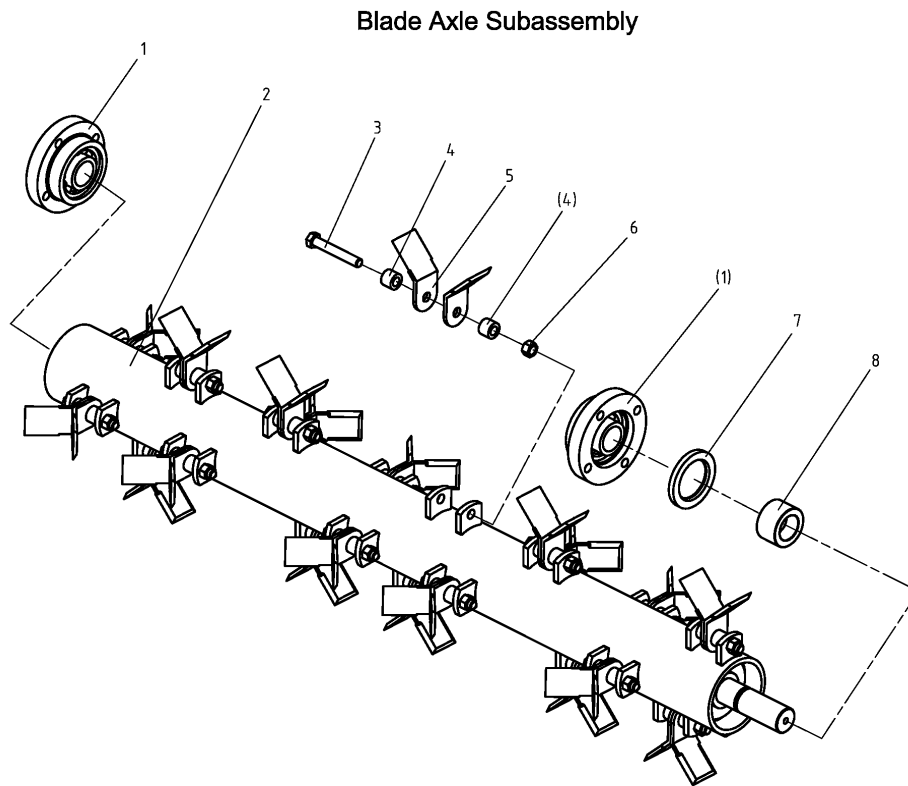

Blade Axle Subassembly			
No.	Part no.	Name & specification	Quantity
1	UC207	90207 bearing	2
2-1	EFG100.013	(105) blade axle	1
2-2	EFG120.013	(125) blade axle	1
2-3	EFG140.013	(145) blade axle	1
2-4	EFG160.013	(165) blade axle	1
3	GB5785-M12X1.5X78	M12X1.5X78 botl	20
4	EF100.00.101	sleeve	40
5-1	EFR105.102	Y blade	40
5-2	EF100.00.102B	hammer	20
6	DIN985-M12X1.5	M12X1.5 nut	20
7	GB13871-FB-55X80X8	FB55X80X8 oil seal	1
8	RK120.109A	(EFG135-175)(L=48)sleeve	1