

Eurotrac W13F

Datablad



STANDARD Udstyr:

- YanMar Stage-V
- Ekstra hydraulisk funktion i joystick
- Hydraulisk hurtigskifte
- 4-cylindret YanMar-dieselmotor
- Hydrostatisk med 2 kørehastigheder
- Navreduktion og differentiellås
- Vejbelysning / arbejdslys



SPECIFIKATIONER:

- | | |
|------------------------------------|-------------------|
| • Motormærke/type | YanMar, 4TN86 |
| • Antal cylindre | 4 |
| • Emissionskrav | Stage-V |
| • Motorkøling | Kølevæske |
| • Maks. ydelse (Kw/Hp/rpm) | 37/50/2600 |
| • Kapacitet (cm ³) | 2434 |
| • Elektrisk system | 12 volt 72 AH |
| • Hydraulikpumpe | Bondioli & Pavesi |
| • Dækstørrelse | 19.0/45-17 |
| • Løftekapacitet, maks. (daN) (kg) | 2480 kg |
| • Maks. arbejdshøjde | 3920 mm |



SPECIFICATIONER:

A.	Samlet længde med standard skovl	4830 mm
B.	Total længde uden skovl	3700 mm
C.	Akselcenter til hurtig skifte	480 mm
D.	Akselafstand	1860 mm
E.	Bagerste overhæng	1190 mm
F.	Maskinhøjde	2250 mm
H.	Sædehøjde	1410 mm
J.	Maks. arbejds højde	3920 mm
K.	Maks. højde hurtigskift	3220 mm
L.	Maks. løftehøjde, vandret	2910 mm
M.	Maks. aflæssehøjde	2315 mm
N.	Min. aflæsseafstand	750 mm
O.	Gravedybde	65 mm
P.	Bredde, total	1340 mm
Q.	Sporbredde	1110 mm
S.	Jordhøjde	255 mm
T.	Maks. yder venderadius med skovl	2635 mm
U.	Maks. venderadius	2320 mm
V.	Maks. inder venderadius	1200 mm
W.	Maks. drejevinkel	45°
X.	Vinklen på skovlen ved maks. højde	43°
Y.	Maks. tippevinkel	45°
Z.	Maks. opkørselsvinkel	28°

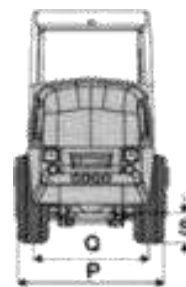
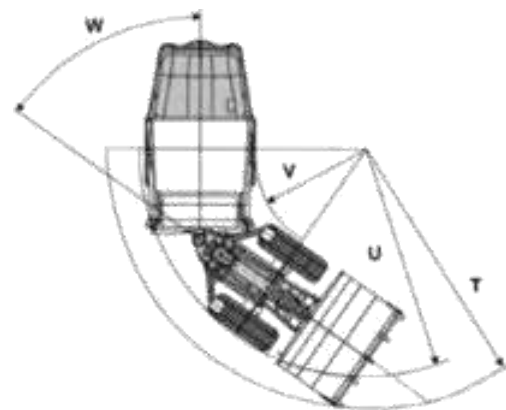
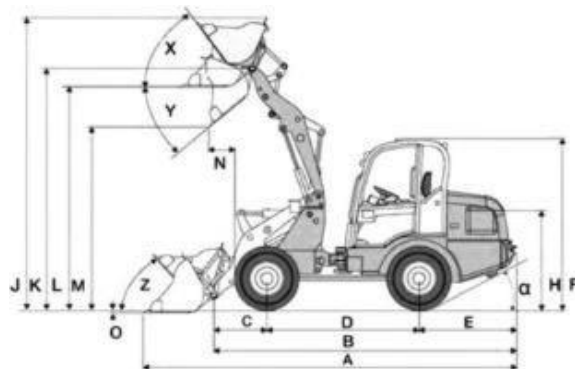

Din forhandler:



J-Maskiner

Stationsvej 2 – 4, DK-6230 Røddekro



+45 20 62 60 66



+45 73 62 60 66



Jos@J-Maskiner.dk



www.J-Maskiner.dk



J-Maskiner

