

Eurotrac W12-F-XL

Datablad



STANDARDUDSTYR:

- Yanmar Turbo STAGE 5 motor på 44 HK
- Hydrostatisk fremdrift
- 2 gear (0- 10/ 0-24 km/t)
- Driftsvægt KUN 2620 kg
- Joystick betjening
- Hydraulisk hurtigskifte
- Ekstra hydraulikudtag
- Arbejdslys/vejlys fuld LED
- Blitzblink
- Skovl
- Pallegafler



SPECIFIKATIONER:

- Motormærke/type Yanmar
- Antal cylindre 3
- Emissionskrav Stage V
- Motorkøling Kølervæske
- Maks. ydelse 44
- Elektrisk system 12 volt/ 70 AH
- Standard (Bred) 09/19/45-17
- Løftekapacitet 1600 kg @ lang arm
(daN) (kg) 1800 kg @ mellem arm
- Løftehøjde 305 cm @lang arm
265 cm @mellem arm

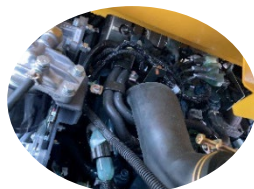

Eurotrac W12-F-XL

Datablad



Specifikationer:

A.	Maskinens bredde	1140 mm
B.	Frihøjde	250 mm
C.	Sporbrede	795 mm
D.	Bredde, total	1600 mm
D1.	Bredde med standard skovl	1150 mm
E.	Maks. arbejds højde	3668 mm
F.	Maks. hurtigskifte	3140 mm
G.	Maks. løftehøjde vandret	2815 mm
H.	Maks. aflæssehøjde	2150 mm
I.	Min. aflæsseafstand	484 mm

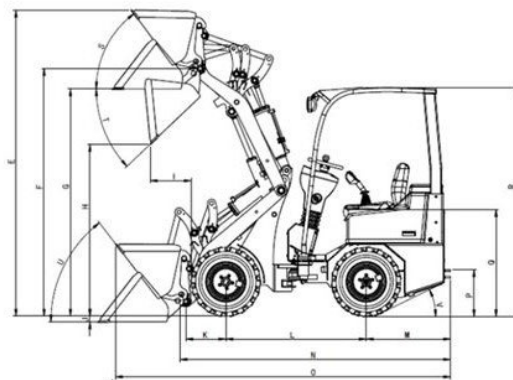

Med mellem arm ska/ der fratrækkes 400mm fra alle højder.

K.	Aksel center til hurtigskifte	708mm
L.	Akselafstand	1750 mm
M.	Udhæng i bagenden	750 mm
N.	Længde uden skovl	3760 mm
O.	Længde med standard skovl	4590 mm
P.	Træhøjde	700 mm
Q.	Sædehøjde	1320 mm
R.	Maskinens højde	2334 mm
S.	Vinklen på skovlen ved maks. Højde	45°
T.	Maks. Tippevinkel	45°
U.	Vinklen på skovlen med armen nede	46°
V.	Maks. Opkørselsvinkel	27°
W.	Maks. Drejevinkel	45°
X.	Maks. Ydre venderadius med skovl	3175 mm
Y.	Maks. Venderadius	2715 mm
Z.	Maks. Indre venderadius	1478 mm

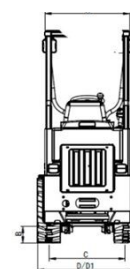
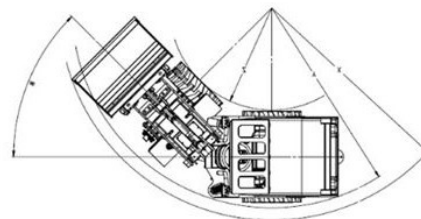

J-Maskiner

Stationsvej 2-4, 6230 Rødekro – Dk



+45 20 62 60 66



+45 73 62 60 66



Jos@J-Maskiner.dk



www.J-Maskiner.dk



J-Maskiner

