

Integral Hydronic Tank

Installation Manual

Attention

Thank you for choosing our product, we shall be more than glad to service you. For you to better operate this product and to prevent accidents due to misoperation, please read carefully this user manual before carrying out any installation or operation, also please pay special attention to the warning, prohibition and attention instructions. We are continuously supplementing and upgrading this user manual to better service for you!

Contents

1. Installation instructions	2
2. Unit structure diagram and size	3
3. Unit installation and usage instructions	5
4. Parameter settings(CGH06HR150-B/CGH-06HR150-B)	15
5. Parameter settings(CGH06HR150/CGH-06HR150).....	18
6. Warning.....	21

Safety precaution

1. Installation instructions

1. Installation should comply with local regulations and requirements.
2. Choose a suitable space for use (please refer to indoor/outdoor unit location selection).
3. Before installation, be sure to confirm the neutral line, L, N, A phase, B phase, C phase, ground line of the user power supply and the neutral line of the heat pump kit, L, N, A phase, B phase, C phase, ground One correspondence.
4. When the heat pump kit needs to be installed or moved. It must be operated by professional refrigeration installation and maintenance personnel. Heat pump kit installed by non-professionals are prone to quality or safety problems.
5. The user should provide a power supply that satisfies the installation and use. The allowable range of voltage that can be used by this product is $\pm 10\%$ of the rated value. If this range is exceeded, it will affect the normal operation of the heat pump kit. If necessary, use a voltage stabilizer to avoid property damage.
6. The heat pump kit must have an independent circuit. The independent circuit needs to install a leakage protector and an automatic circuit breaker. Need to be purchased by the user.
7. The heat pump kit should be installed in accordance with the national wiring regulations.
8. The heat pump kit must be grounded correctly and reliably, otherwise it may cause electric shock or fire
9. Please do not turn on the power of the heat pump kit until the piping and wires are connected and carefully checked.

2. Unit structure diagram and size

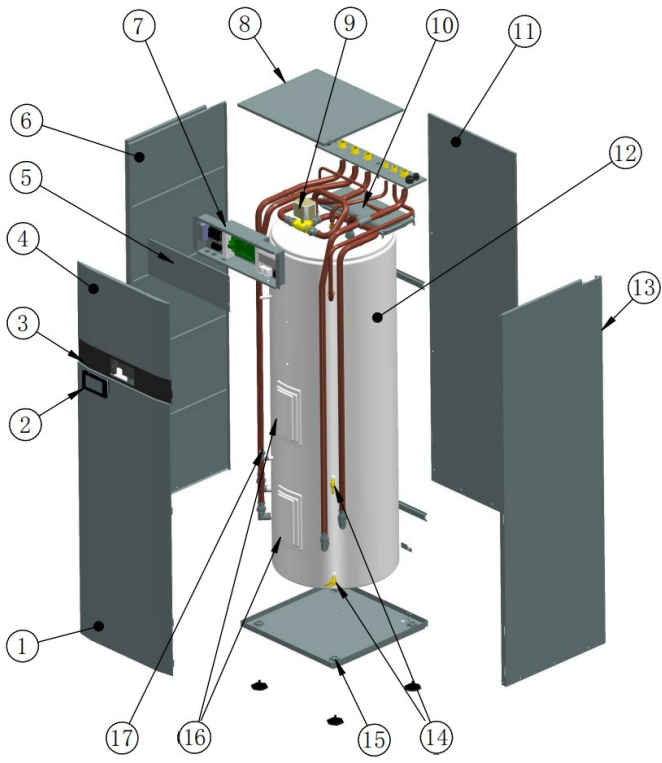

No.	Component	No.	Component
1	Lower Front Panel	10	Expansion Tank
2	Control Panel	11	Back Panel
3	Front Middle Panel	12	Double Bile Water Tank
4	Front Upper Panel	13	Right Panel
5	Electric Box Cover	14	Blowdown Valves

6	Left Panel	15	Chassis
7	Electrical Box	16	Electric Heater Cover
8	Top Cover	17	Automatic Exhaust Valve
9	Three-way Valve	18	

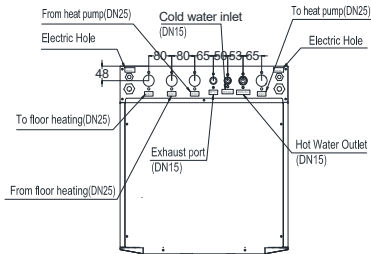
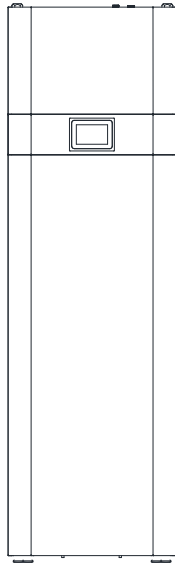

For all models

3. Unit installation and usage instructions

3.1 System installation diagram

Notice:

1. Pls select the right modes according to your demand then install it according to the installation diagram. If only hot water function required, pls select heating+hot water mode , and then put the hot water sensor into the hot water tank.
2. Two-way valve and BV valve are optional for installation. Only if you need to control the temperature by different zone, then pls install both.
3. Fan coil can be controlled by linkage with the secondary circulation pump . Meanwhile, a passive linkage thermostat shall be installed.
4. If the unit does not have a built-in circulating water pump P1, an additional circulating pump needs to be installed, and the control line can be connected to the interior of the Integral Hydronic Tank

Symbol	Name
	Ball valve
	Filter
	Water pump
	Temp sensor
	Release valve
	Safety valve
	Active connector

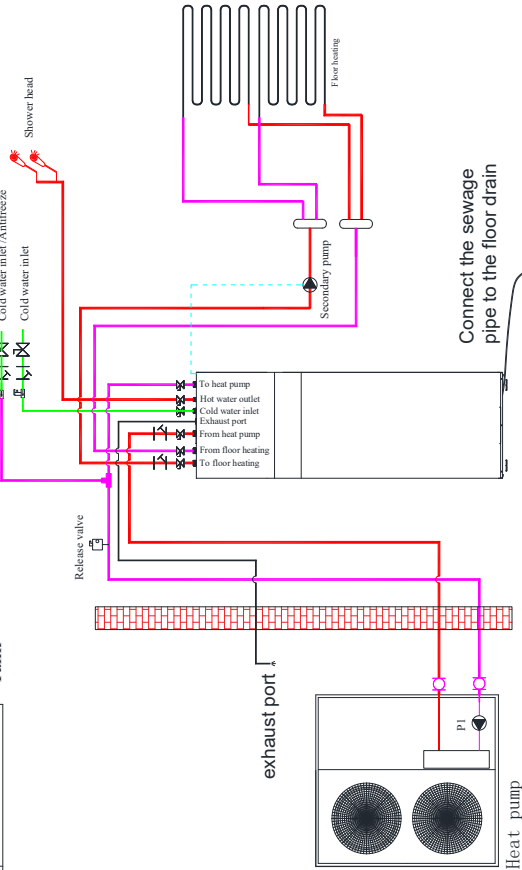









Single temperature zone system diagram

Single temperature zone

Notice:

1. Pls select the right modes according to your demand then install it according to the installation diagram. If only hot water function required, pls select heating+hot water mode , and then put the hot water sensor into the hot water tank .
2. Two-way valve and BV valve are optional for installation. Only if you need to control the temperature by different zone, then pls install both.
3. Fan coil can be controlled by linkage with the secondary circulation pump . Meanwhile, a passive linkage thermostat shall be installed.
4. The proportional three-way valve in temperature zone 2 is powered by a 24V power supply and controlled by a 0-10V voltage signal. If you need this function, please be sure to choose a suitable three-way valve.
5. If the unit does not have a built-in circulating water pump P1, an additional circulating pump needs to be installed, and the control line can be connected to the interior of the Integral Hydronic Tank

Symbol	Name
	3-way valve
	Ball valve
	Filter
	Water pump
	Temp sensor
	Release valve
	Safety valve
	Active connector

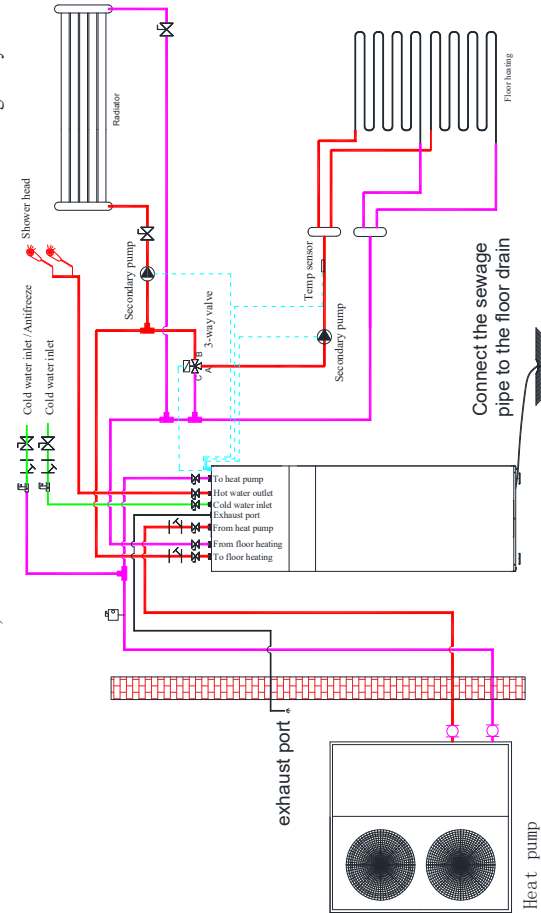

Dual temperature zone system diagram

Dual temperature zone

Using instructions for proportional control valve at temp. zone 2 (take DQF-B-225*DQQ-B3M-05-24AC for example)

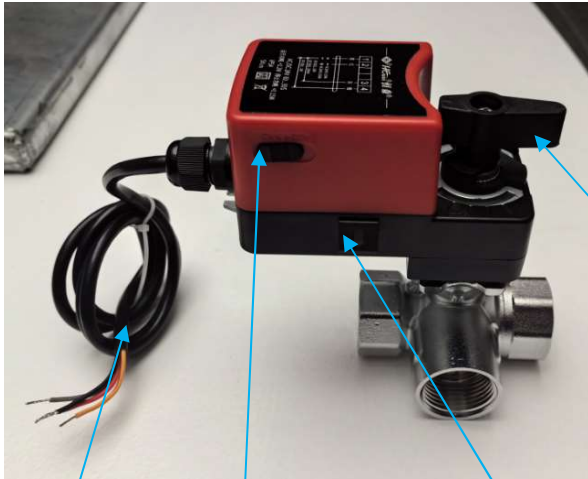

control lines

Turning direction
adjustment
button

Manual
Adjustment
Switch

Manual
Adjustment
Knob

Control line wiring: wiring according to the circuit diagram, as follows

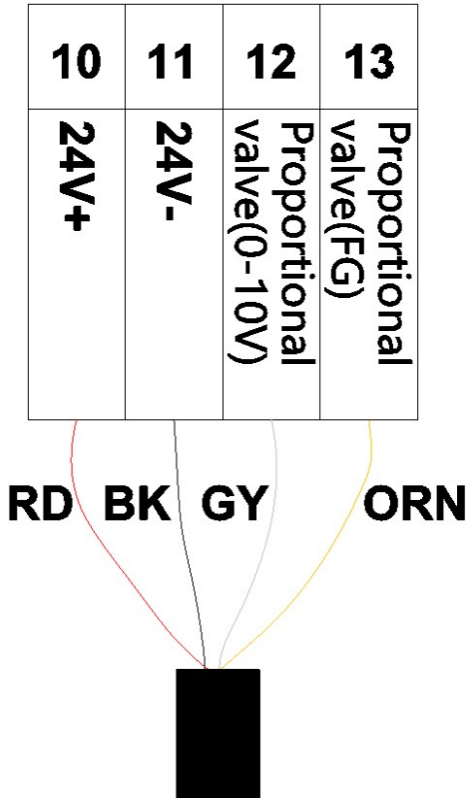

Turning direction adjustment button: used to switch the turning direction of the valve , when the return pipe and mixing pipe are connected to the opposite, can be switched by this button, without changing the pipeline.

Manual Adjustment switch: In addition, this valve has a manual adjustment function. When automatic control is not required (cut off the power supply of the valve), press the valve button down to turn the **[manual adjustment knob]** for manual opening adjustment. Note that the manual adjustment knob must be pressed under the manual adjustment

switch can be turned on;

Note that the valve body A, B, C interfaces should not be connected to the wrong. See the figure below for details:

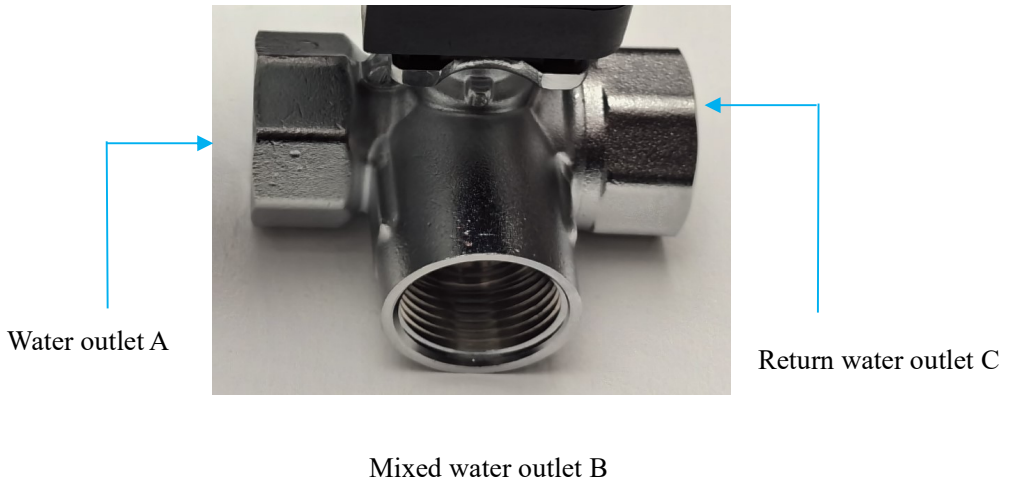

3.2 System wiring diagram

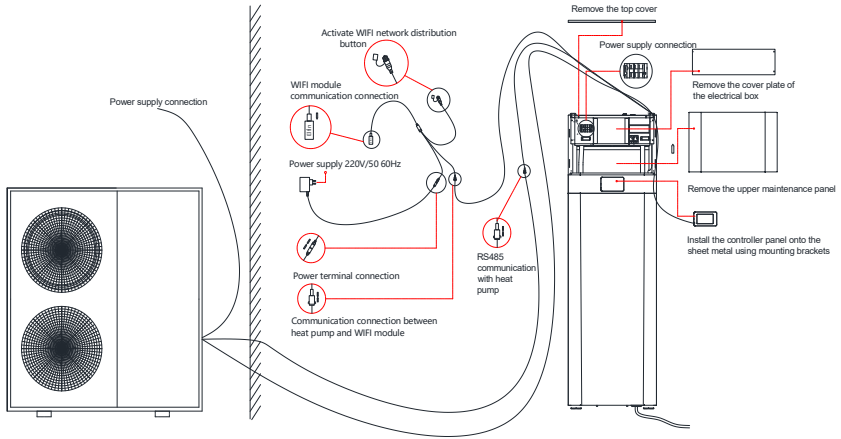

For CGH06HR150、CGH-06HR150

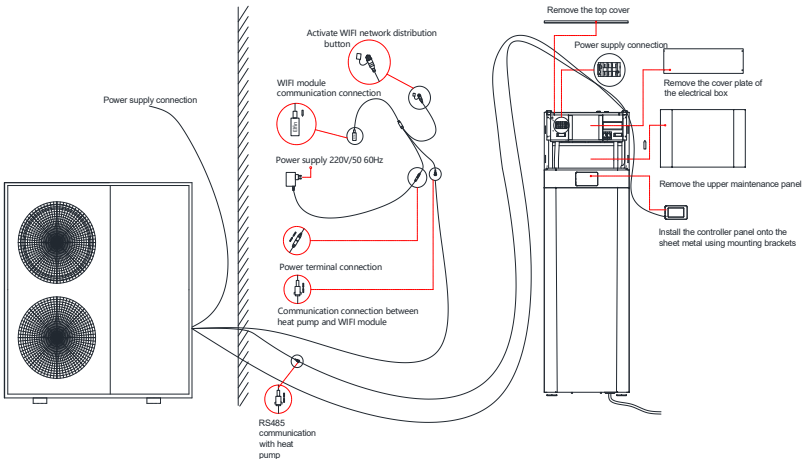

For CGH06HR150-B、CGH-06HR150-B

Attention: There is electric heating inside the Integral Hydronic Tank , so a residual current action protector must be installed for electrical safety.

3.3 Unit cable diameter selection:

Model	Maximum current	Power Cord Diameter
CGH06HR150/CGH06HR150-B	27.2A	6mm ²
CGH-06HR150/CGH-06HR150-B	15.7A	4mm ²

3.4 Wiring diagram:

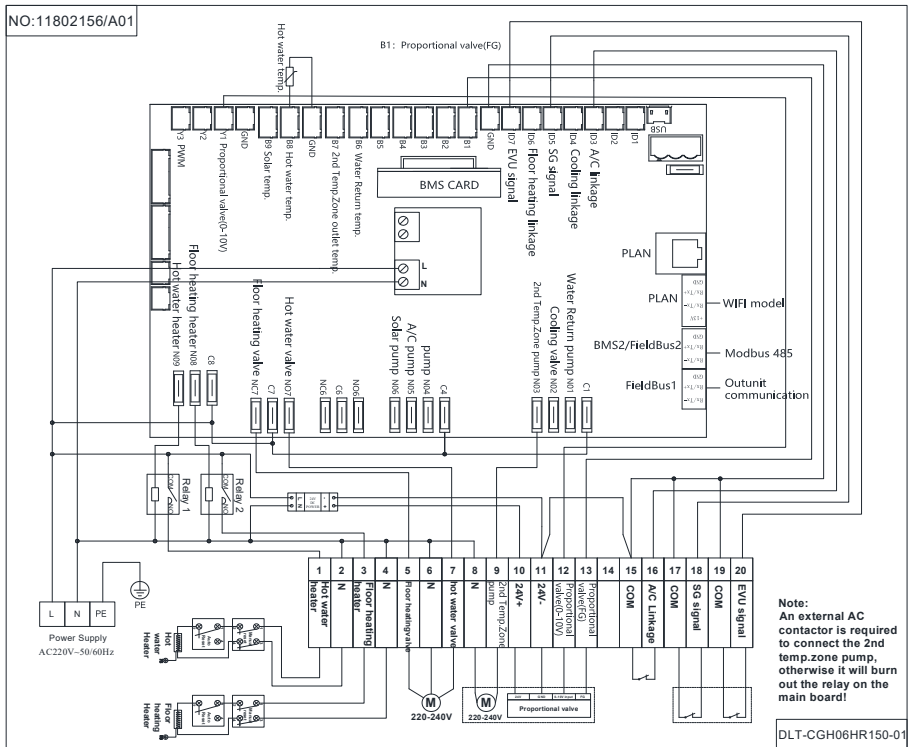

For CGH06HR150

NO:11802154/A01

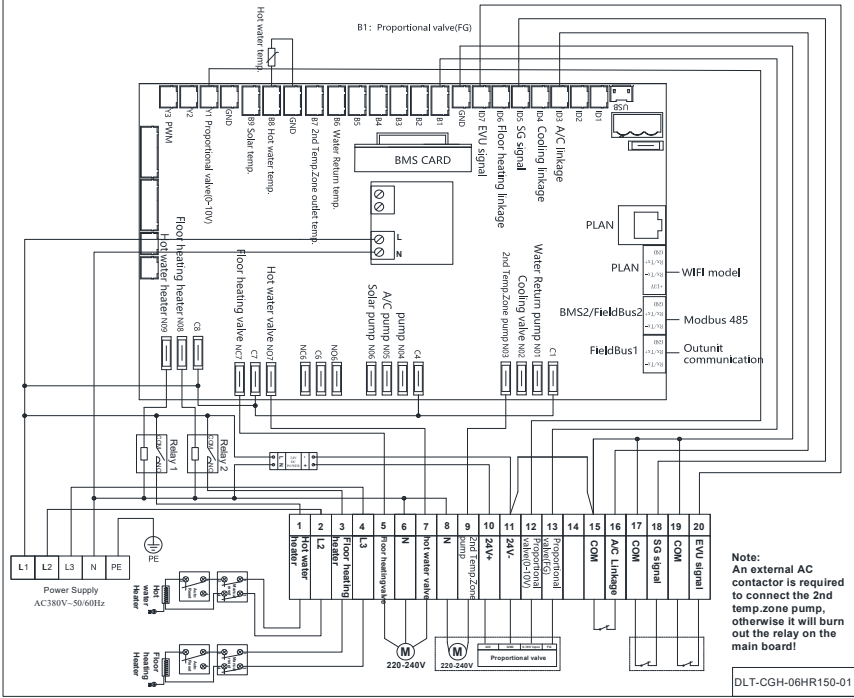

For CGH-06HR150

NO:11802155/A01

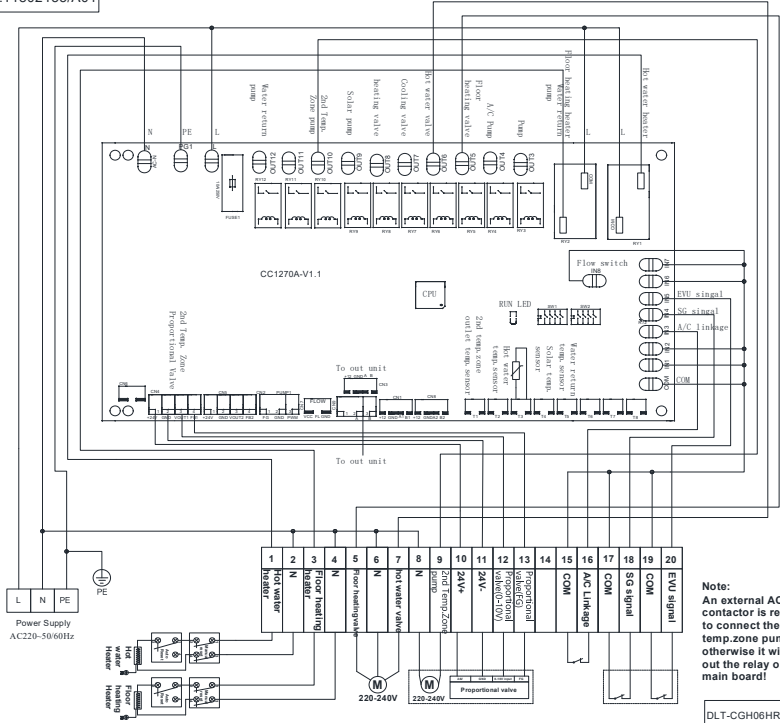

Note:
An external AC contactor is required to connect the 2nd temp. zone pump, otherwise it will burn out the relay on the main board!

DLT-CGH06HR150-B-01

For CGH06HR150-B

NO:11802157/A01

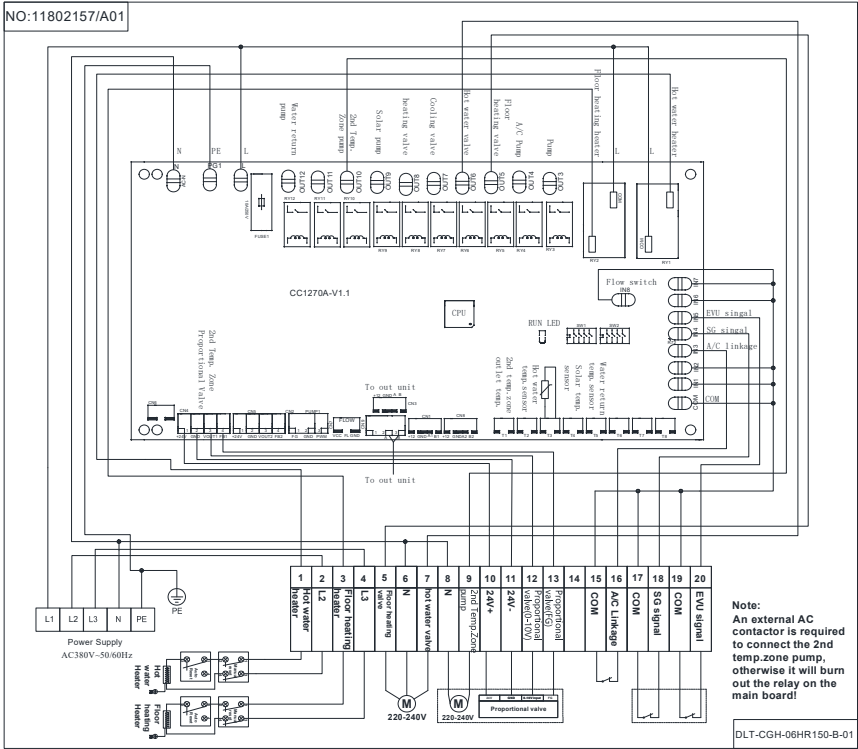

For CGH-06HR150-B

3.5 Parameter settings description:

Please follow the electric heating instructions provided with the host to make relevant settings.

4: Parameter settings

(CGH06HR150-B/CGH-06HR150-B) :

4.1 Click "" on the main screen to enter the "MAIN MENU" page.

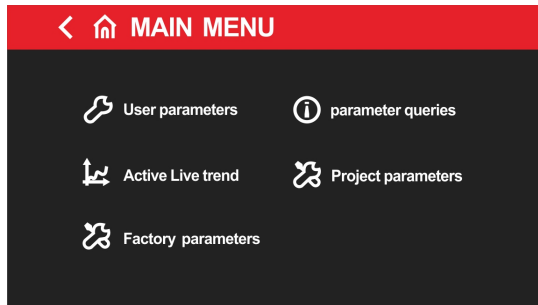

4.2 Click " Project parameters" on the "MAIN MENU" page and enter the password 0816 to enter the "Project paraters" page.

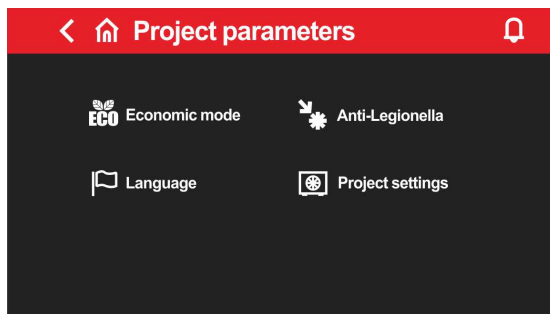

4.3 Click " Project settings" on the "Project paraters" page to enter the "Project settings" page.

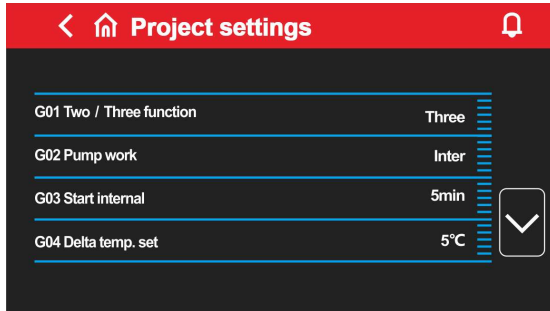

4.4 Click the "" button continuously until the page turns to G25:

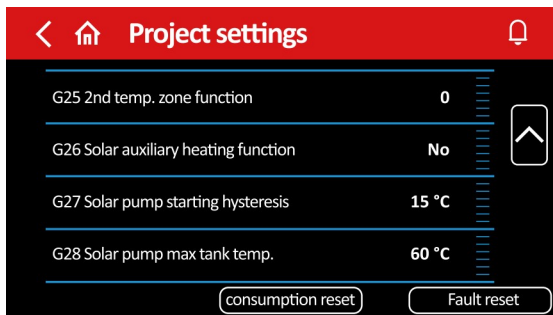

4.4.1 In the picture above, set G25 to 1 to turn on the 2nd temp. Zone function, and set it to 0 to turn off the 2nd temp. zone function; When the 2nd temp. zone function is turned on, the indoor unit function is enabled at the same time. At this time, the "2nd temp. zone 2 setting" parameter P08 is displayed in the user parameters, this parameter is used to set the water supply temperature of temperature zone 2.

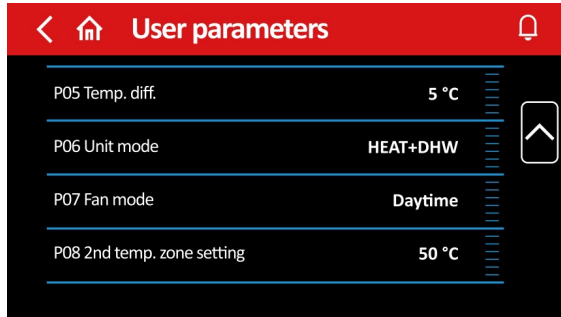

4.4.2 Set G26 to 1 to turn on the solar auxiliary heating function, and set it to 0 to turn off the solar auxiliary heating function.

4.4.3 G27 is used to set the solar pump starting hysteresis, when the temperature of the solar sensor and hot water tank are greater than or equal to this hysteresis, the solar pump will start to heat the hot water tank.

4.4.4 G28 is used to set the upper limit of the hot water tank temperature during solar heating. When the hot water tank temperature is higher than this value, the solar pump will stop running.

5: Parameter settings

(CGH06HR150/CGH-06HR150) :

5.1 Click "" on the main screen to enter the "MAIN MENU" page.

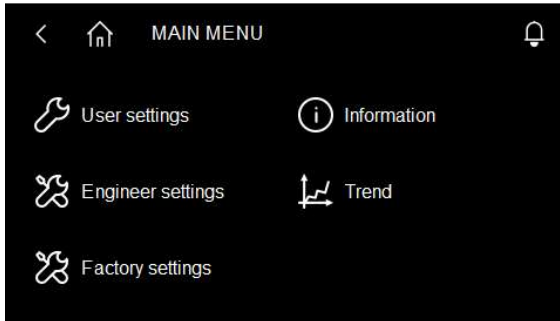

5.2 Click " Engineer settings" to enter "Engineer settings Menu" page.

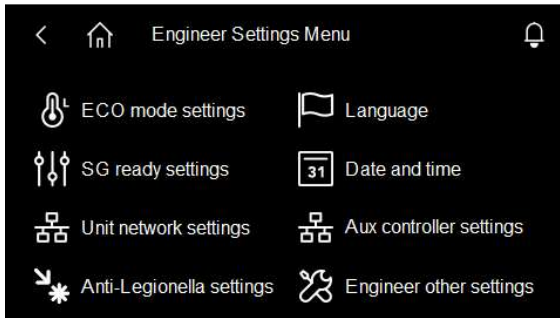

5.3 Click " Aux controller settings" to enter "Aux controller settings" page.

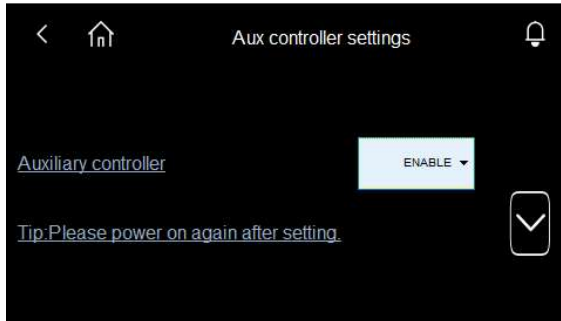

5.3.1 On this page, you can choose to enable or disable the auxiliary controller. The system default is "DISABLE". When the user uses this multi-function water box, please set this option to "ENABLE" and power on the host again to be effective.



5.3.2 On this page, click on the “” button to enter the other parameters of the auxiliary controller.

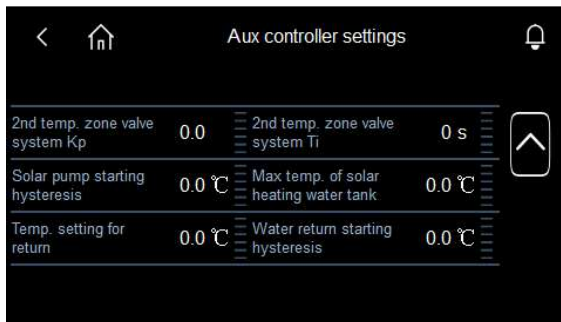

2nd temp.zone valve system kp: The second temperature zone proportional valve PID adjusts the proportional coefficient.

2nd temp.zone valve system Ti: The second temperature zone

proportional valve PID adjusts the integral coefficient.

Solar pump starting hysteresis: Solar water pump start-up return difference, when the temperature of the solar sensor and hot water tank are greater than or equal to this hysteresis, the solar pump will start to heat the hot water tank.

Max temp. of solar heating water tank: set the upper limit of the hot water tank temperature during solar heating. When the hot water tank temperature is higher than this value, the solar pump will stop running.

Temp.setting for return: domestic hot water return water temperature set point, When the actual return water temperature is equal to or greater than this value, the return water pump stops running.

Water return starting hysteresis: return water pump start-up return difference.

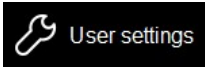
5.4 In "MAIN MENU" click " User settings" to enter "user settings" page.

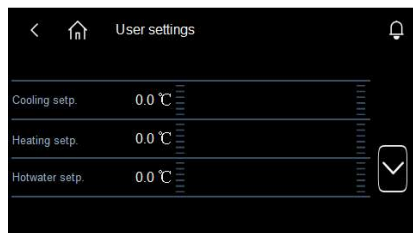



5.4.1 Click “” on this page to enter “Aux controller user settings” page.

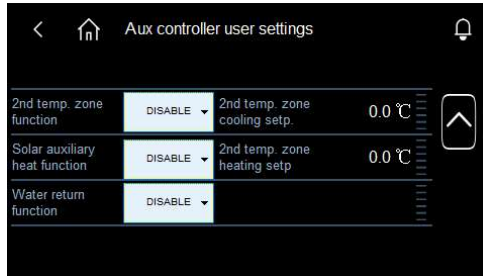

2nd tmeq. Zone function: enable or disable the second temperature zone function.

2nd tmeq. Zone cooling setp: set the outlet water temperature of the second temperature zone in the cooling mode.

2nd tmeq. Zone heating setp: set the outlet water temperature of the second temperature zone in the heating mode.

Solar auxiliary heat function: enable or disable the solar auxiliary heat function.

Water return function: enable or disable the domestic hot water return function.

6: Warning:



1: The inlet pipe needs to be installed with a filter, and the density of the filter screen is more than 60Mesh;

- 2: The inlet pipe needs to be installed with a safety valve, which needs to be installed in accordance with the drawings, otherwise it will cause damage due to excessive pressure inside the water tank;
- 3: The external pipeline all need insulation measures to prevent heat loss, condensation and icing;
- 4: The water quality should be in line with the municipal tap water standards, prohibit the use of ground water and corrosive liquids.
- 5: When using for the first time, please make sure that the hot water tank and buffer tank are full of water, the water outlets have water flow, and the system air is discharged before switching on and running;
- 6: There is electric heater inside the unit, the power supply must be installed with residual current action protector to prevent electric shock.;
- 7: The exhaust port should be taken over and led to the outdoor, and regularly (3 months) to check whether there is any blockage or water accumulation. If so, clean it;
- 8: The magnesium rod must be replaced regularly. The general replacement cycle is about one year. It is located at the magnesium rod mark on the front of the fuselage;
- 9: To prevent inconvenience or property damage caused by water leakage from pipe connections or normal drainage when the safety valve releases pressure, the unit is prohibited from being installed in indoor areas without floor drains. Additionally, the equipment's sewage pipes and the safety valve's drainage pipes should be directed to floor drains.

CERTIFICATE

Product Model: _____

Bar code: _____
